

916-BATDT-M

Installation and Operating Instructions



9201 Independence Avenue • Chatsworth, CA 91311
(818) 407-3420 • FAX (818) 700-1961

CONTENTS

Specifications	1
Battery Installation and Replacement	2
Dimensions	3
Theory of Operation.....	4
Wiring	5
Typical Applications	5
Definitions.....	6
Programming Flowchart	9
Operation	11
Error Messages	12
Analog Output Calibration	12
Warranty	13
Decoding Part Number	13
Appendix A - RS232 Option S1	14
Appendix B - RS485 with Modbus Protocol Option S2.....	19

SPECIFICATIONS

Description

Featuring 5 digits of resettable total and 8 digits of grand total, the 916-BATDT-M is a battery powered indicator capable of accepting magnetic pickup, DC pulse and switch closure inputs from pulse producing flowmeters. A scaled pulse output is standard. A 4-20mA loop and/or linearization is optional.

Specifications

POWER:

BATTERY POWERED

Supplied with 2 C size Lithium battery pack.

EXTERNAL POWER INPUT

Voltage: 8.5 to 30 VDC

Current: Less than 5 mA

Supplied with 1 C size lithium battery for standby operation

Protection: Reverse Polarity Protection on DC Power Input

LOOP POWERED

Voltage: 8.5 to 30 VDC

Supplied with 1 or 2 C size lithium battery(ies) for standby operation

Protection: Reverse Polarity Protection on Current Loop

Loop Burden: 8.5V maximum

BATTERY LIFE EXPECTANCY:

Expected Years of Operation for 916-BATDT-M of various powering options at equipment duty cycles

MODEL

RUN TIME

	Idle	2hrs/day	8hrs/day	24hrs/day
916-BATDT-M-A	10 yrs	10 yrs	10 yrs	9.1 yrs
916-BATDT-M-A-4	10 yrs	10 yrs	10 yrs	8.4 yrs
916-BATDT-M-B/C standby-operation	10 yrs	10 yrs	10 yrs	10 yrs
916-BATDT-M -B/C External or loop power	Indefinite operation when externally powered			

NOTE: Battery shelf life is rated at 10 years by manufacturer Life expectancy based on rated battery capacity at 20°C

The above table is shown with pulse output inactive. Use of pulse output shortens battery life. **Example:** A pulse output of 0.06 sec. duration, once per second, would derate the battery life by 20%.

DISPLAY:

Resettable Total Display

5 Digits (99999), 0.35" High, Display updates once every second (8 times per second if loop powered)

Grand Totalizer Display: (selectable decimal)

8 Digits (99999999), 0.2" High

Totalizer Descriptors: GAL, LIT, FT3, M3, "blank"

Warning Displays: Low battery warning

PULSE OUTPUT:

The pulse output advances with the least significant digit of the totalizer or decimal multiples thereof (see Pulse scale divider).

Type: Isolated photomos relay

Max. voltage (off state): 30 VDC

Current (on state): 100mA

Pulse Duration: Selectable 0.5, 0.25, 0.125, 0.0625 seconds

Pulse Scale divider (Pulscale): User selectable, ÷1, ÷10, ÷100 or OFF

NOTE: Select OFF for max. battery life.

ACCURACY:

±1 count

ENVIRONMENTAL:

OPERATING TEMPERATURE

-4°F (-20°C) to +158°F (70°C)

Extended Temp: -22°F (-30°C) to +158°F (70°C)

HUMIDITY

0 - 90% Noncondensing

MOUNTING STYLES:

- 1- Panel Mount - NEMA 4X Front
- 3- Explosion Proof - Class I, Division I, Groups B, C & D
Class II, Division I, Groups E, F & G
NEMA 4X Enclosure
- 5- Wall Mount - (keypad mounted on cover)
- 6- Double Ended Explosion Proof - Class I, Division I, Groups B, C & D
Class II, Division I, Groups E, F & G
(contact factory for details)

INPUTS:

MAGNETIC PICKUP INPUT

Frequency Range: 0 to 3500 Hz

Trigger Sensitivity: 10 mV p-p

Over Voltage Protected: ± 30 VDC

OPTO-ISOLATED DC PULSE INPUT

High (logic 1): 4-30 VDC

Low (logic 0): Less Than 1 VDC

Minimum Current: .5 mA

Hysteresis: 0.4 VDC

Frequency Range: 0 to 5 kHz

Min. Pulse Width: 0.1 msec

CONTACT CLOSURE INPUT (contact closure to common)

Internal Pullup Resistor: 100 KΩ to +3.6 VDC

High (logic 1): Open or 4-30 VDC

Low (logic 0): Less Than .5 VDC

Internal Switch Debounce Filter: 0 to 40 Hz

NOTE: Sustained contact closure will shorten battery life.

RESET INPUT (contact closure to common)

Internal Pullup Resistor: 100 KΩ to +3.6 VDC

High (logic 1): Open or 4-30 VDC

Low (logic 0): Less Than .5 VDC

Minimum On : 25 msec

NOTE: Sustained contact closure will shorten battery life.

K-FACTOR

Range: 0.001 to 99999999

Decimal Point Locations: XXXX.XXXX to XXXXXXXX

20 Point Linearization Option (10 Point with S2 option)

This feature allows the user to enter 20 different frequencies with 20 different corresponding K-Factors to linearize non linear signals.

ANALOG OUTPUT OPTION:

Type: 4-20 mA follows rate computation, Two wire hookup

Accuracy: 0.025% Full Scale at 20°C

Temperature Drift:

50 ppm/°C Typical

Reverse Polarity Protected

Update Rate: 8 times/second

NOTE: The 916-BATDT-M uses the 4-20 mA loop power as its primary power source when this option is used. The battery is still required for standby battery operation. Selectable analog output damping.

COMMUNICATIONS OPTION (S1):

RS232 SERIAL SETUP SOFTWARE OPTION:

This option enables you to access a variety of process parameters through serial communications. PC compatible communications software is included with this option. With this software and a 916-BATDT-M Serial Adapter Cable (BSAC1) you will be able to setup the 916-BATDT-M through your PC.

DATA STORAGE:

Setup Information: Stored in flash memory

Totalizer: Stored in battery backed RAM but can be saved to flash memory by operator for recall after battery change out.

RS-485 MODBUS and DATA LOGGER OPTION (S2):

The optional RS-485 card utilizes Modbus RTU protocol to access a variety of process parameters. The Data Logger stores the totalizer to flash memory once every 24 hours at the time you set. Requires external DC power.

BATTERY INSTALLATION and REPLACEMENT

Battery Installation:

All 916-BATDT-M models are shipped without the battery(ies) installed. This preserves battery life when the unit is not in service. When using external BATPACK, mount within 12" and plug connector into 3 position square posts (see Fig 1). Polarity is not a concern because center is common.

To install the battery, begin by locating the battery holder. The 916-BATDT-M-3, 5 and 6 require opening the enclosure cover and removing the 916-BATDT-M to expose the battery holder.

The plus terminal of the battery is marked with a (+) symbol stamped into the battery holder. Be sure to install the battery(ies) correctly.

Install battery(ies) to begin setup procedure. See Programming Flowchart to setup desired operating parameters.

Battery Replacement:

The 916-BATDT-M has a battery monitor feature which illuminates when the lithium battery voltage approaches its end of life. A descriptor, "BAT", illuminates when the battery voltage falls below this predetermined value. The low battery detector operates correctly with all power options.

The battery, or batteries, should be replaced within several weeks of the first occurrence of low battery warning, "BAT". Left unattended, the unit may become inaccurate, cease to operate or malfunction.

Before replacing the battery(ies), Press the ← (left arrow) key to save the totalizer. The display will show "SAVE TOTAL". This will save the current total value and the total will resume from this value when the new battery(ies) is(are) installed. **NOTE:** If the display starts to flash after the "SAVE TOTAL" message times out, press the "E" (enter) key. If the message "E FLASH" is displayed, then there was not enough power left to save the setup and totalizer to flash memory. At this point you must record the totalizer and setup information and re-enter the setup data after the new battery(ies) is(are) installed.

Install new battery(ies) as described above.

Fig 1

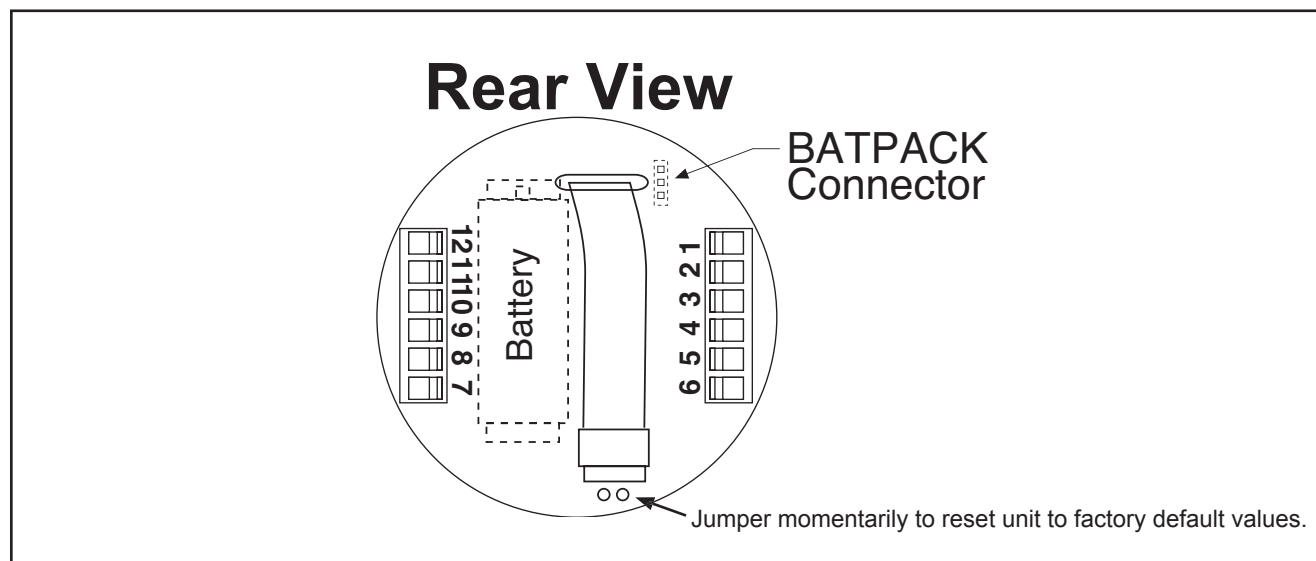

DIMENSIONS

BATPACK

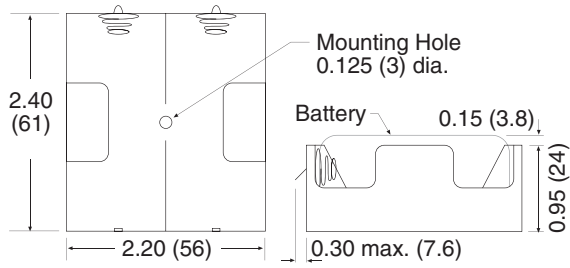

916-BATDT-M-3

To access terminals, unscrew cover and loosen 2 panel screws. Terminals are on bottom side of PC board.

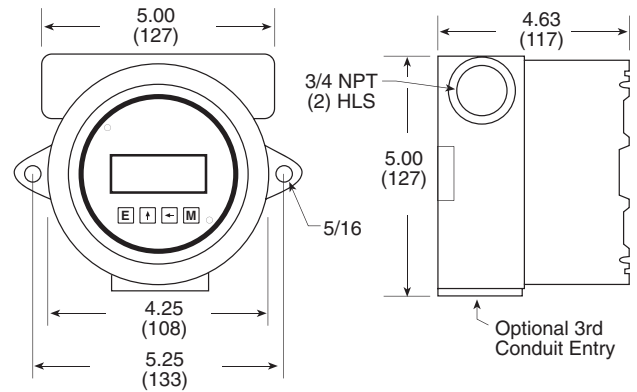

916-BATDT-M-1

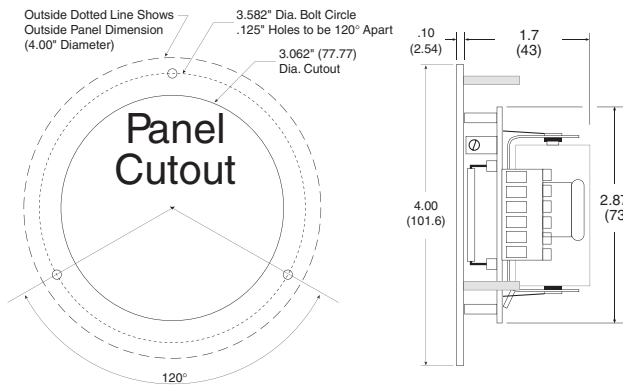

916-BATDT-M-5

#8 Screw Mounting holes molded directly under cover screws. Max. screw head .29" (Typ. 4 places)

To access terminals, remove cover. Terminals are on bottom side of PC board.

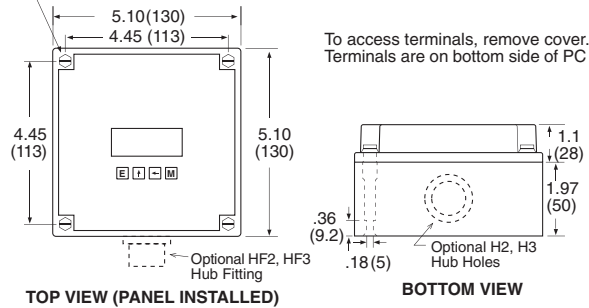

NOTE: Additional conduit entries available upon request.

916-BATDT-M-6

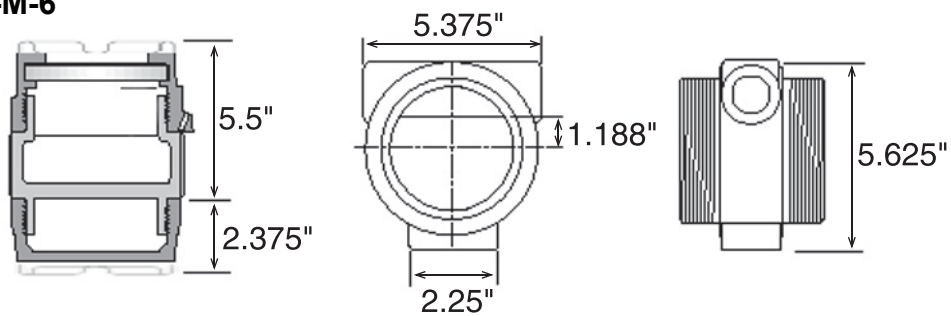

THEORY OF OPERATION

Flow total equation:

$$\text{Flow Total} = \frac{\text{Sum of Input Pulses}}{\text{FAC}}$$

Flow rate equation:

$$\text{Flow Rate} = \frac{\text{Input Frequency}}{\text{FAC}} \times \text{Time Scaler}$$

Where Time Scaler is equal to: 1 for rate per second read out
60 for rate per minute read out
3600 for rate per hour read out
86400 for rate per day read out
"D" option Only

NOTE: The unit computes the rate for the analog output

20 Point Linearization Option: (10 Point with S2 option)

A 20 point linearization table is used to construct a curve describing the relationship of K-Factor and input frequency. The measured input frequency is used to access the table. A linear interpolation of adjacent point pairs is used to arrive at the K-Factor at that input frequency. The flow rate and total are then computed based upon the K-Factor for that measurement sample.

NOTE: For best performance and resolution choose as many decimal places as possible in the K-Factor.
Example: Enter a K-Factor of 1 as 1.000.

WIRING

Several typical applications of the 916-BATDT-M are shown below. Please observe that the various pulse inputs and power options may be intermixed in many ways to solve common applications. The isolated pulse output may be freely used so long as proper polarity is observed.

Caution: When 4-20 mA loop option is provided, the power wiring to the loop power option should always be to terminals (+) 12 and (-) 11. Accidental wiring to (+) 12 and (-) 6 should be avoided since excessive current flow may result.

Caution: The magnetic pickup input and contact closure input require isolated sensors for proper operation. Accidental connections to earth may result in erroneous operation of the analog output and/or excessive current flow.

Caution: Accidental connections from circuit common (3 or 6) to earth or terminal (11) may result in erroneous operation of the analog output and/or excessive current flow.

TYPICAL APPLICATIONS

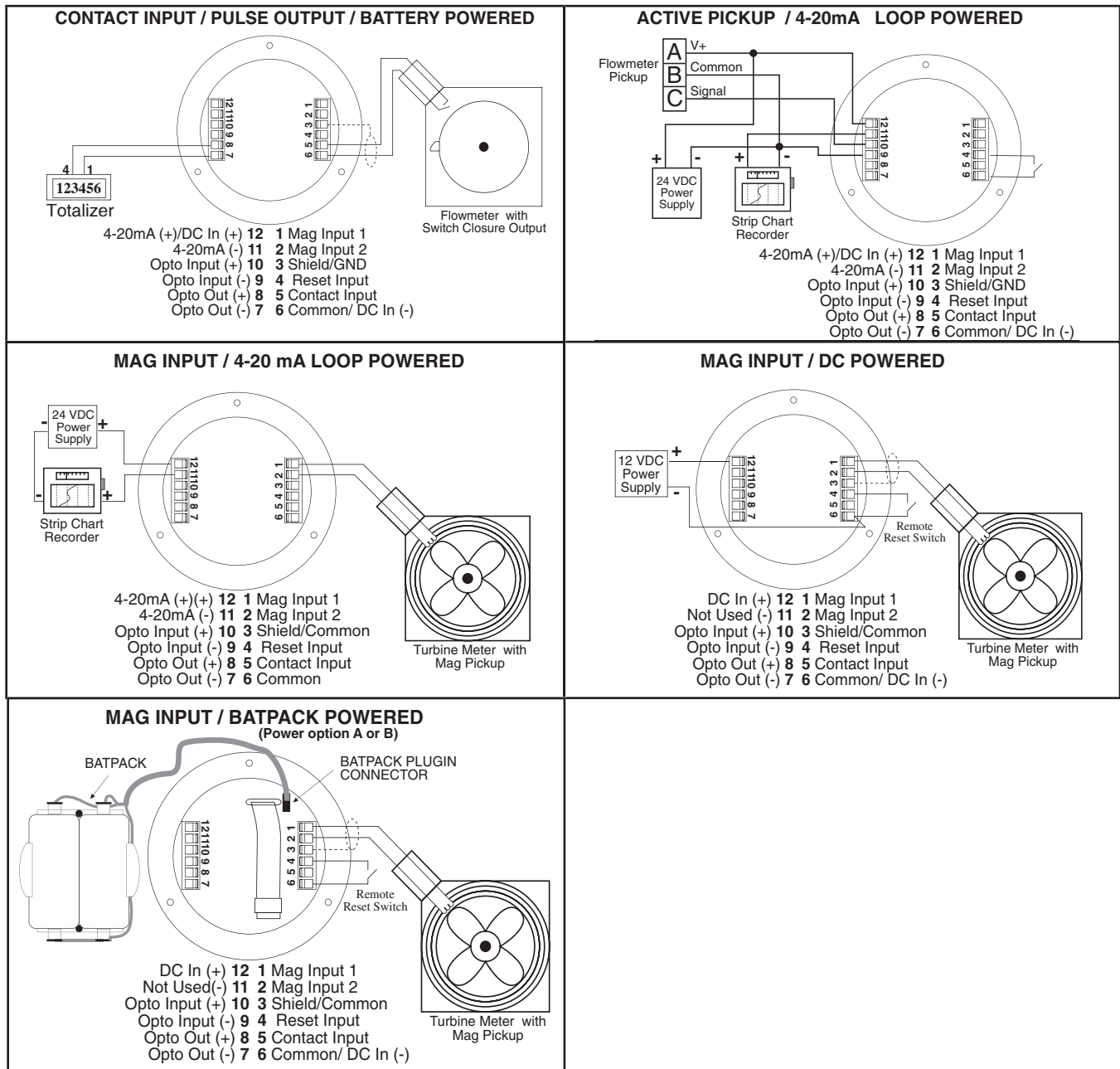

DEFINITIONS

SRUE ŁŁŁRL: (Save Total) Press the **E** key while the unit is running to save the total value. The display will show "SRUE ŁŁŁRL" for a few seconds. This is a very useful "scratch pad" to save and restore total when replacing the battery(ies)

ŁŁŁ ŁŁŁŁ: (enter code) This prompt will only appear if the panel lock is ON. Press the \uparrow key to increment each digit. Press the \leftarrow key to step to the next digit to the left. Press the **E** key to enter the 5 digit code. If the entered code is correct, the display will advance to the next menu prompt (**ŁŁŁ ŁŁŁŁ**). If incorrect, the display will return to the run mode.

ŁŁŁ ŁŁŁŁ: (clear total) Clears (resets) the grand totalizer. Press the **E** key to clear the grand total and return to the run mode. Press the **M** key to skip and advance to the next menu selection.

FŁŁŁ: (factor decimal) Sets the decimal location for the factor. This location is restricted to 3 places (99.999). The use of this decimal automatically limits the number of decimal locations allowable in the rate and total to acceptable ranges. Press the \leftarrow key to move the decimal. Press the **E** key to select the displayed decimal location.

NOTE: For best performance and resolution choose as many decimal places as possible in the K-Factor.
Example: Enter a K-Factor of 1 as 1.000.

FRL ŁŁŁŁŁŁ/ŁŁŁŁŁŁ: (factor type) This prompt will only appear if the unit is ordered with the 20 point linearization option. The **ŁŁŁŁŁŁ** linearization selection is recommended for flow meters whose K-factors change with different flow rates. This selection allows users to enter up to 20 different frequencies with 20 corresponding K-factors for different flow rates. The **ŁŁŁŁŁŁ** setting is used for flow meters whose output is linear over its' entire operating flow range. Press the \uparrow key to step to the desired choice. Press the **E** key to enter the displayed factor type.

ŁŁŁ / ŁŁŁ ŁŁŁ ŁŁŁŁ: (set 20 point?) This prompt allows the user to skip the 20 point setup routine. Select **ŁŁŁ** for initial setup or to change the present 20 point values. Select **ŁŁŁ** to skip and keep the existing values.

FRL : (factor) This prompt appears on all units with linear inputs. The Factor is the number of pulses per unit volume for the flow sensor. The pulses/unit volume is implied by the totalizer descriptor when a descriptor is used. The implied units for the Factor are then as follows:

<u>Standard</u>		<u>"D" Option</u>	
GAL	pulses/gallon	GAL	pulses/gallon
LIT	pulses/liter	BBL	pulses/BBL
FT3	pulses/ft3	MCF	pulses/MCF
M3	pulses/M3	M3	pulses/M3

Factors from 0.0001 to 99999999 may be used. A "0" value for the factor is not allowed and the unit will default to "1" in LSD if a "0" entry is attempted. The factor is displayed on the subsidiary (lower) display. Press the \uparrow key to increment each digit. Press the \leftarrow key to step to the next digit to the left. Press the **E** key to enter the displayed factor.

Fr# : (frequency for point #) This prompt will only appear when 20 point selected. It sets the frequency for each of the 20 points (#). Press the \uparrow key to increment each digit. Press the \leftarrow key to step to the next digit to the left. Press the **E** key to enter the desired frequency for point #.

FRL# : (factor for point #) This prompt will only appear when 20 point selected. It sets the factor for each of the 20 points (#). Press the \uparrow key to increment each digit. Press the \leftarrow key to step to the next digit to the left. Press the **E** key to enter the desired factor for point #.

NOTE: The display will advance to the next point (Fr#) after each entry of the Fr & Fac until all 20 points are complete. entering a 0 in the Fr or fac setting will advance the display to the next menu prompt (**ŁŁŁŁŁŁ**).

DEFINITIONS (continued)

tDEC: (totalizer decimal) Sets the decimal location for the totalizer. The totalizer decimal is not a dummy decimal and will scale the totalizer display accordingly. (i.e. if the tdec is set in the tenths position (1234567.8), 100 will be displayed as 100.0). The location of the decimal point allows for greater resolution of both the totalizer display and the pulse output. The pulse output advances at a rate dependent on the least significant digit of the totalizer. The totalizer decimal location is restricted to a maximum of 4 places (1234.5678). However, the number of totalizer decimal locations allowable is reduced with each decimal place added to the factor decimal. Press the ← key to move the decimal. Press the **E** key to enter the displayed decimal location.

Note: The selection of the factor decimal point limits the available selections for the number of decimal points available for the totalizer. This is automatic. Enter your selection of the Factor's decimal point before entering the totalizer decimal point to assure the proper selection of the totalizer decimal point has been made.

tDESC: (totalizer descriptor) This allows you to illuminate one of the available descriptors on the display (STD: GAL, LIT, FT3, M3 or "blank"; "D" option: GAL, BBL, MCF, M3, "blank"). Press the ↑ key to select the descriptor. Press the **E** key to enter the selected descriptor.

rSCALE: (ratemeter scaling) Sets the timebase for the ratemeter which is used for the analog output. Choose rate per hour (HrS), minutes (MIN) or seconds (SEC). (Days will appear on units ordered with the "D" (rate per day) option.) The scale setting is shown on the main (upper) display. Press the ↑ key to step to the desired choice. Press the **E** key to enter the displayed scale setting.

Note: A rate descriptor corresponding to the above choice will be illuminated on the display.

rDECLOC: (ratemeter decimal location) Sets the decimal location for the ratemeter which is used for the analog output. The ratemeter decimal is not a dummy decimal and will scale the rate display accordingly. (i.e. if the r decloc is set in the tenths position (123.4), 100 will be displayed as 100.0). The ratemeter decimal location is restricted to a maximum of 4 places (.1234). However, the number of ratemeter decimal locations allowable is reduced with each decimal place added to the factor decimal. Press the ← key to move the decimal. Press the **E** key to enter the displayed decimal location.

NOR # NORMALIZING FACTOR - Normalizes (averages or dampens) the flow rate data being received. Enter a value from 0 to 9. Higher settings provide more normalizing (averaging) for a more stable display. Derived from the equation:

$$\frac{(\text{Old Data} \times \text{"NOR"} + \text{New Data})}{(\text{"NOR"} + 1)}$$

DELAY: (delay) Sets the amount of time (0.1 to 99.9 seconds) that the unit will "look" for valid input data. If pulses are not detected within this "window", the rate will be computed as 0 and the analog output will read 4mA. The output will update once every second as long as the unit receives valid data within a second. Some internal mathematics may delay this update. Press the ↑ key to increment each digit. Press the ← key to step to the next digit to the left. Press the **E** key to enter the displayed delay value.

out Lo: (out low) Sets the low setting for the 4-20 mA analog output. Key in the low rate value at which the unit will output 4mA. Press the ↑ key to increment each digit. Press the ← key to step to the next digit to the left. Press the **E** key to enter the displayed out lo value.

out Hi: (out high) Sets the high setting for the 4-20 mA analog output. Key in the high rate value at which the unit will output 20 mA. Press the ↑ key to increment each digit. Press the ← key to step to the next digit to the left. Press the **E** key to enter the displayed out hi value.

DEFINITIONS

(continued)

PULSE: (pulse out scaling) This allows the unit to output a pulse for each least significant total count divided by the selected divider. The pulse out can be divided by 1 (1), 10 (10), 100 (100), or turned off (OFF). With the divider set at 1, the unit will give a pulse out for every increment of the LSD displayed.

Note: For maximum battery life, turn the pulse output off when pulse output is not used.

Selecting the proper pulse output divider may be needed so that the pulse output does not exceed the maximum rate of the pulse output. If the pulse output pulses too quickly a flashing display will result. Pressing the "M" key will result in a display of an error message "E PULSE". Press the "E" key to return to the run mode.

PULSE: (pulse width) Sets the pulse width of the pulse output. Selections are: 0.5 (1Hz), 0.25 (2Hz), 0.125 (4Hz) or 0.0625 (8Hz). This menu item is skipped if PULSE is turned off.

LOCK: (lock code) Sets the 5 digit lock code to be entered when the unit prompts Enter Code. This allows the user to gain access to the menu when the unit is locked. Press the ↑ key to increment each digit. Press the ← key to step to the next digit to the left. Press the E key to enter the displayed code.

Record this number for later use!

LOCK CODE: _____

LOCK: (lock unit) Sets the panel lock ON or OFF. Press the ↑ key to select On or OFF. Press the E key to enter the displayed selection.

NOTE: Units equipped with RS232 option S1, refer to Appendix A for additional definitions.

NOTE: Units equipped with RS485 Modbus option S2, refer to Appendix B for additional definitions.

PROGRAMMING FLOWCHART

NOTE: Units equipped with RS232 option S1, refer to Appendix A.

NOTE: Units equipped with RS485 Modbus option S2, refer to Appendix B.

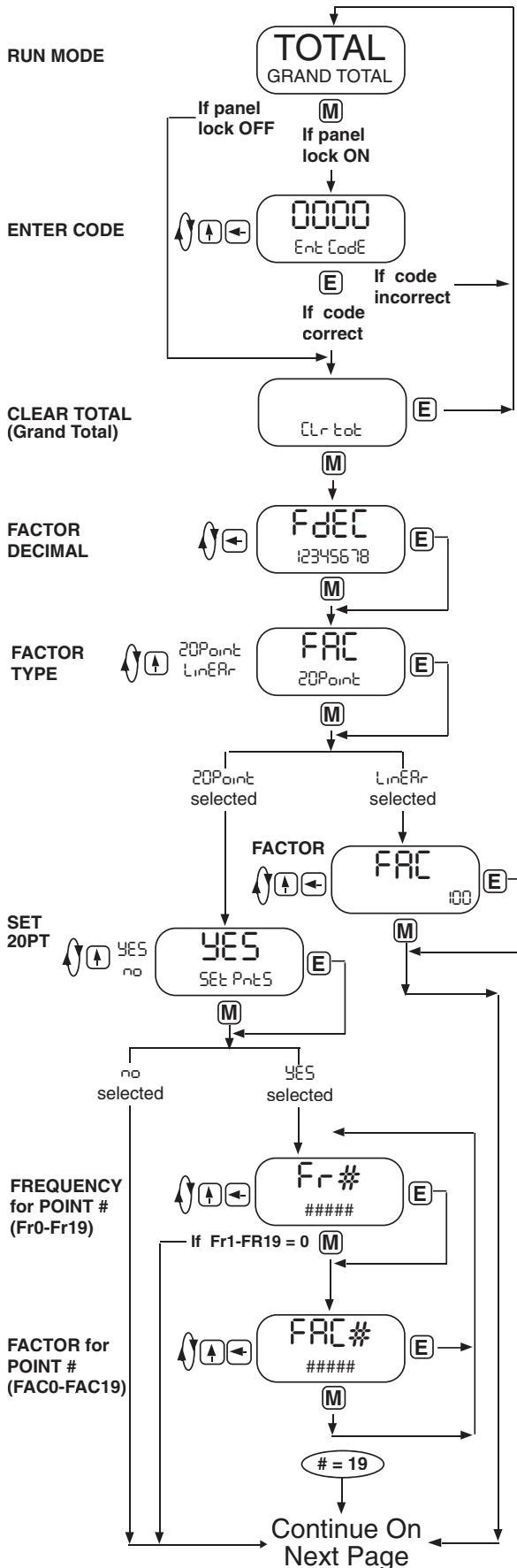

Press the **M** key to enter the programming menu.

If the panel lock is on, you must enter the 4 digit lock code to gain access to the menu.

Press the **↑** key to increment each individual digit of the code.

Press the **←** key to advance to the next digit.

Press the **E** key to enter the displayed code.

If the code is correct, display advances to "Clr Tot", if not, display returns to run mode

Press the **E** key to clear the Grand Totalizer and return to the programming menu.

Press the **M** key to skip and go to next menu item.

Press the **←** key to step the factor decimal to the desired location.

Press the **E** key to enter the displayed decimal location.

Press the **M** key to skip and keep the existing location

NOTE: For best performance and resolution choose as many decimal places as possible in the K-Factor. Example: Enter a K-Factor of 1 as 1.000.

Press the **↑** key to choose factor type (20Point or LinERr).

Press the **E** key to enter the displayed factor type.

Press the **M** key to skip and keep the existing factor type.

The FAC prompt will only appear if LinERr is selected or if the unit was ordered without the 20 point linearization option.

Press the **↑** key to increment each individual digit of the factor.

Press the **←** key to advance to the next digit.

Press the **E** key to enter the displayed factor.

Press the **M** key to skip and keep the existing factor.

The SET PntS prompt will only appear if 20Point is selected. This allows users to bypass the 20 point set up and keep the existing values.

Press the **↑** key to choose YES or NO.

Press the **E** key to enter the displayed selection.

Press the **M** key to skip (same as selecting NO).

Press the **↑** key to increment each individual digit of the frequency for point #.

Press the **←** key to advance to the next digit.

Press the **E** key to enter the displayed frequency.

Press the **M** key to skip and keep the existing frequency.

If 0 is entered, the display will advance to the next prompt (tdec).

NOTE: Frequency/factor point pairs must be entered in ascending order of frequency

Press the **↑** key to increment each individual digit of the factor for point #.

Press the **←** key to advance to the next digit.

Press the **E** key to enter the displayed factor.

Press the **M** key to skip and keep the existing factor.

If 0 is entered, the display will advance to the next prompt (tdec).

PROGRAMMING FLOWCHART

(continued)

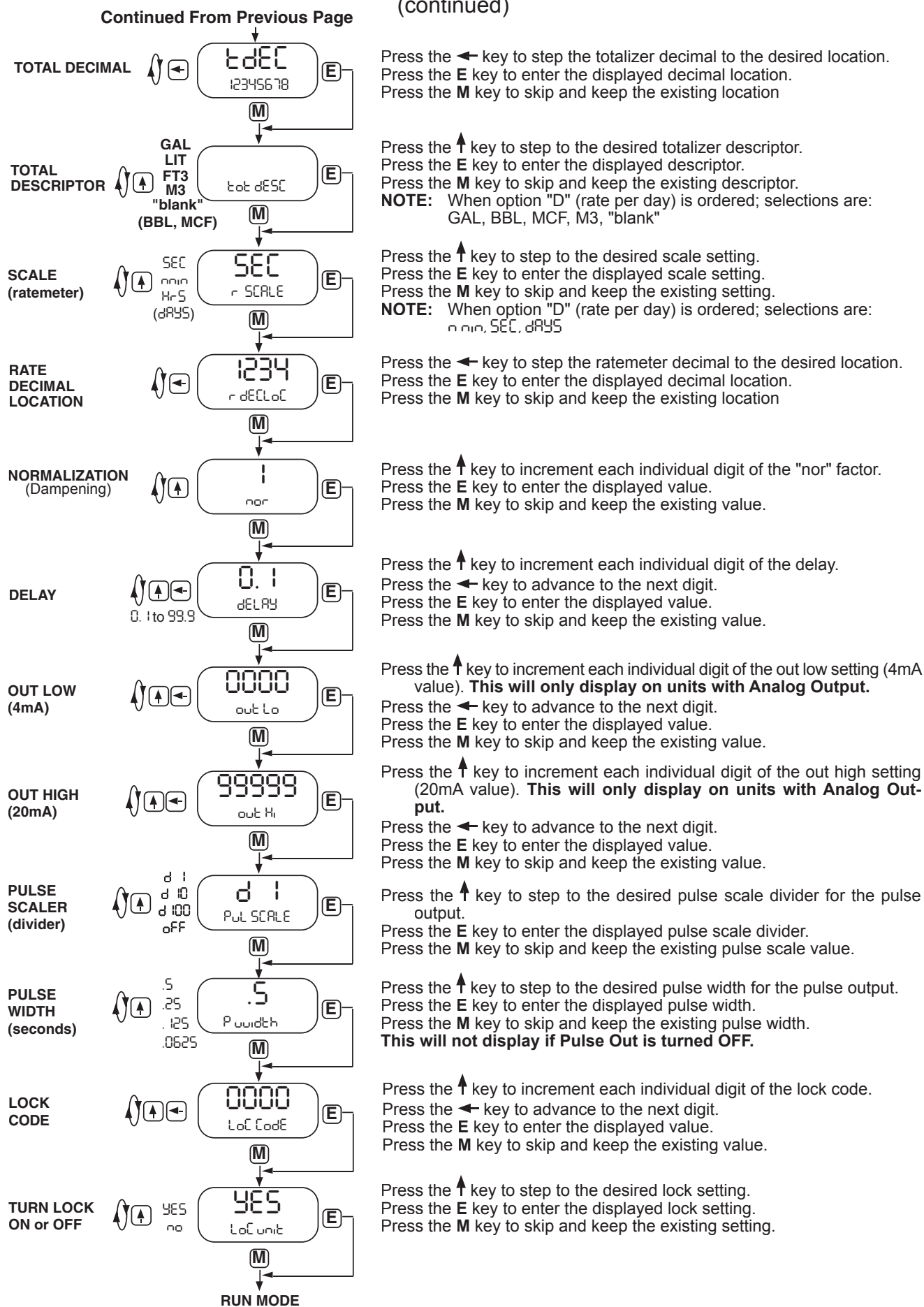

OPERATION

A suitable pulse producing device or flow meter is wired to one of the three pulse inputs provided on the 916-BATDT-M. Only one of these inputs is used in a given application. There are no connections to the two unused pulse inputs.

Isolated magnetic pickups may be connected to terminals 1 and 2. Isolated contact closures may be connected to terminals 5 and 6. Any high level, DC pulse type may be connected to terminals 9(-) and 10(+).

Power to the unit may be provided by internal batteries, external DC, or the current loop. In all cases, the internal battery will provide for continued operation in the event primary power is lost.

Once properly wired, the operation of the 916-BATDT-M is automatic.

The flow totalizer is updated once per second* with battery power, 8 times per second with DC or loop power. If no input counts are received the unit remains in a low power state to conserve power.

The flow total may be cleared by the front panel switch sequence or by a contact closure on the remote reset terminal to circuit common.

RESETTING THE TOTALIZERS:

Grand Total: The grand total may be cleared only by using the following key sequence:

- Press **M** "CLr tot" will be displayed (if the panel lock is on, the display will prompt "Enter Code").
Enter the proper code to advance to the CLr tot prompt)
- Press **E** To clear the total. Unit will return to operation

5 Digit Total: The 5 digit total can only be reset by a contact closure on the remote reset terminal to circuit common.

The flow rate computation will measure the flow rate once every second* with battery power, 8 times per second with DC or loop power and display the flow rate.

If the input pulses are not detected within the delay setting (0.1 to 99.9 seconds), a flow rate of 0 will be indicated.

The analog output will be scaled based on the user selected zero and full scale and the measured flow rate. The analog output is updated at the same time as the rate display.

The pulse output updates at the same rate as the total display in accordance with the instrument setup of pulse scaling.

* Slow input pulse rates, large delay setting and internal math operations may delay the update rate of information. A faster update rate occurs when the unit is loop powered or externally powered.

KEYPAD OPERATION:

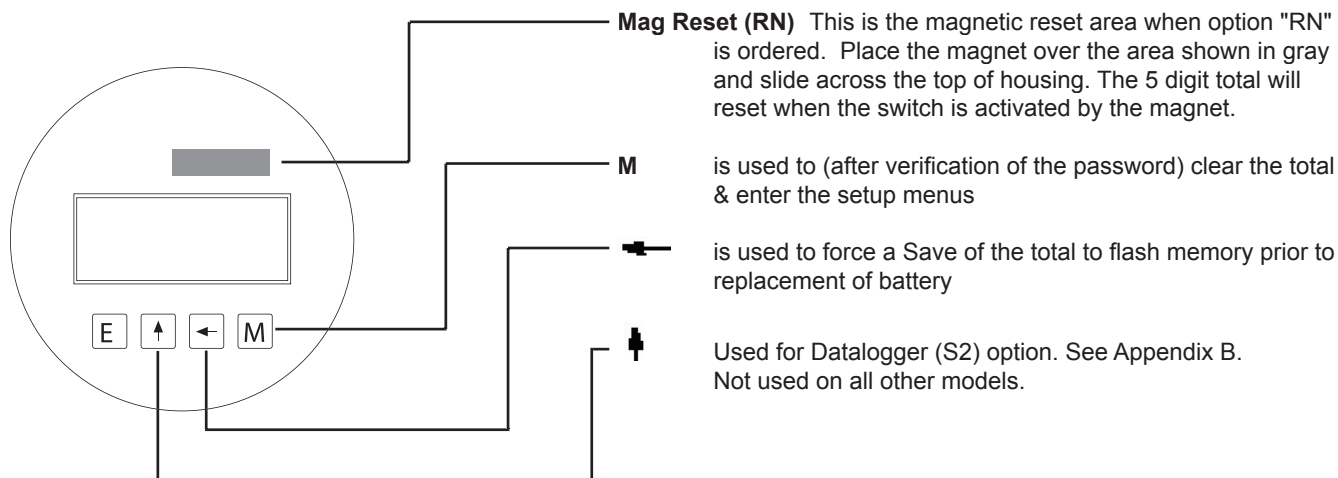

Note:

1. See also setup mode for description of its operation
2. See also Calibration Section for description of its Operation

ERROR MESSAGES

The 916-BATDT-M is provided with extensive self checking which assists the user in the location of setup entry errors and in reporting malfunctions or unusual operating conditions. When an error occurs, the display will flash. Press any key to see the error message corresponding to the error that has occurred. Press any key again to acknowledge the error. (If the error can be eliminated by a change of setup values, the unit will automatically advance to the MENU so that the appropriate setup changes can be made).

Table - 2 illustrates the warning message, problem, and recommended corrective actions.

Diagnostic Error Messages Table-2

WARNING MESSAGE	CAUSE	CORRECTIVE ACTION
"BAT" Descriptor	Low Battery	Replace battery(ies)
E TOTAL	Total rollover	None required
RATE Err	Rate value for analog low set higher than rate value for analog high.	Set rate value for analog high greater than rate value for analog low.
E RATE	Computed rate exceeds 99999	Use lower rate dec point
FAC Err	Factor = 0	Enter a factor other than 0
E PULSE	Pulse out Overflow	Use different pulse scaler or totalizer decimal point
E FLASH	Save to flash memory failed	Write down displayed total and setup values if you are changing the battery. If total wasn't saved, it will display an arbitrary total when new battery is installed. In this case, reset the total to 0 and check the setup information.

ANALOG OUTPUT CALIBRATION

CAUTION: Performing the analog output calibration will erase all programming values. Please record all programmed values before beginning the analog output calibration

If the unit is equipped with the analog output option, the 4-20 mA has been accurately set to 4.000 and 20.000 mA by the factory. No calibrations should be required.

The 4-20 mA output may be verified periodically by installing a digital milliamp meter(DMM) in series with the analog output and simulating a full scale or over range flow rate.

If the output is out of calibration, perform the following:

Remove power and/or disconnect battery(ies). Hold down the scroll (↑) key and replace the battery. This will initialize the unit and advance to the analog output calibration mode. Connect a DMM set to read current in series with a power supply (8.5 to 30 volts DC) to TB12 (+) and TB11 (-). The output should read 4.000 ma (± 0.005). If it does not, Adjust the numbers on the display up or down until the output reads 4.000 ma (± 0.005). Press the "E" key. The DMM should now read 20.000 ma (± 0.005). If it does not, Adjust the numbers on the display up or down until the output reads 20.000 ma (± 0.005). Press "E" and the unit will return to the "RUN" mode.

Ordering Information

EXAMPLE: 916-BATDT-M 3 A 4 ET

Series: _____

Mounting: _____

- * 1 = Panel Mount
- 3 = Explosion Proof Housing
- 5 = NEMA 4X Box (916-BATDT-M outside opaque cover)
- 6 = Double Ended Explosion Proof Housing (consult factory)

Power Supply: _____

- * A = Battery (2 supplied)
- B = External Power Supply (8.5 to 30 VDC)
- C = Loop Powered with 4-20 mA Output
- AC = Loop Powered with 4-20 mA Output and 2 Batteries

Options (Multiple Options Available) _____

- S1 = Serial Setup Software for use with BSAC1
- S2 = RS485/Modbus/Data Logger - Isolated (power options B, C only)
- 4 = 20 Point Linearization (10 point with S2 option)
- D = Rate per Day, Hour or Minute
- ET = Extended Temp.: -22°F to 158°F (-30°C to 70°C)
- CE** = CE Compliant
- CSA** = CSA Listed Explosion Proof
- IS** = UL Listed IS (planned)
- TRX = NEMA7 Explosion Proof Reset Switch (mounting style 3 and 6)
- RN = External Magnetic Reset
- T = Third Conduit Entry in Ex-Proof Housing (mounting style 3 and 6)
- H2 = 0.875" Hole for mounting style 5
- HF2 = 0.5" Female NPT Hub fitting for mounting style 5
- H3 = 1.125" Hole for mounting style 5
- HF3 = 0.75" Female NPT Hub fitting for mounting style 5

Accessories:

- BATPACK= External Batt. Pack with 2 C Size Batteries & 12" leads
- BATC = Single Battery: Tadiran P/N TL2200/S 3.6V 7200mAh or equal
- 115-24 = 115 VAC to 24 VDC power supply
- BSAC1 = RS232 Serial Adapter Cable with setup software

* External battery pack supplied with model 916-BATRT-M1A

** Contact factory for latest information

WARRANTY

This product (excluding batteries) is warranted against defects in materials and workmanship for a period of two (2) years from the date of shipment to Buyer.

The Warranty is limited to repair or replacement of the defective unit at the option of the manufacturer. This warranty is void if the product has been altered, misused, dismantled, or otherwise abused.

ALL OTHER WARRANTIES, EXPRESSED OR IMPLIED, ARE EXCLUDED, INCLUDING BUT NOT LIMITED TO THE IMPLIED WARRANTIES OF MERCHANTABILITY AND FITNESS FOR A PARTICULAR PURPOSE.

DEFINITIONS

SRUE tōtRL: (Save Total) Press the **E** key while the unit is running to save the total value. The display will show "SRUE tōtRL" for a few seconds. This is a very useful "scratch pad" to save and restore total when replacing the battery(ies)

Ent CōdE: (enter code) This prompt will only appear if the panel lock is ON. Press the ↑ key to increment each digit. Press the ← key to step to the next digit to the left. Press the **E** key to enter the 5 digit code. If the entered code is correct, the display will advance to the next menu prompt (CLr tot). If incorrect, the display will return to the run mode.

CLr tōt: (clear total) Clears (resets) the totalizer. Press the **E** key to clear the total and return to the run mode. Press the **M** key to skip and advance to the next menu selection.

FdEC: (factor decimal) Sets the decimal location for the factor. This location is restricted to 3 places (99.999). The use of this decimal automatically limits the number of decimal locations allowable in the rate and total to acceptable ranges. Press the ← key to move the decimal. Press the **E** key to select the displayed decimal location.

NOTE: For best performance and resolution choose as many decimal places as possible in the K-Factor.

Example: Enter a K-Factor of 1 as 1.000.

FAC LINER/20POINT: (factor type) This prompt will only appear if the unit is ordered with the 20 point linearization option. The 20 POINT linearization selection is recommended for flow meters whose K-factors change with different flow rates. This selection allows users to enter up to 20 different frequencies with 20 corresponding K-factors for different flow rates. The LINER setting is used for flow meters whose output is linear over its' entire operating flow range. Press the ↑ key to step to the desired choice. Press the **E** key to enter the displayed factor type.

no / YES SET POINTS: (set 20 point?) This prompt allows the user to skip the 20 point setup routine. Select YES for initial setup or to change the present 20 point values. Select no to skip and keep the existing values.

FAC : (factor) This prompt appears on all units with linear inputs. The Factor is the number of pulses per unit volume for the flow sensor. The pulses/unit volume is implied by the totalizer descriptor when a descriptor is used. The implied units for the Factor are then as follows:

<u>Standard</u>		<u>"D" Option</u>	
GAL	pulses/gallon	GAL	pulses/gallon
LIT	pulses/liter	BBL	pulses/BBL
FT3	pulses/ft3	MCF	pulses/MCF
M3	pulses/M3	M3	pulses/M3

Factors from 0.0001 to 99999999 may be used. A "0" value for the factor is not allowed and the unit will default to "1" in LSD if a "0" entry is attempted. The factor is displayed on the subsidiary (lower) display. Press the ↑ key to increment each digit. Press the ← key to step to the next digit to the left. Press the **E** key to enter the displayed factor.

Fr# : (frequency for point #) This prompt will only appear when 20 point selected. It sets the frequency for each of the 20 points (#). Press the ↑ key to increment each digit. Press the ← key to step to the next digit to the left. Press the **E** key to enter the desired frequency for point #.

FAC# : (factor for point #) This prompt will only appear when 20 point selected. It sets the factor for each of the 20 points (#). Press the ↑ key to increment each digit. Press the ← key to step to the next digit to the left. Press the **E** key to enter the desired factor for point #.

NOTE: The display will advance to the next point (Fr#) after each entry of the Fr & Fac until all 20 points are complete. entering a 0 in the Fr or fac setting will advance the display to the next menu prompt (tdec).

tōdEC: (totalizer decimal) Sets the decimal location for the totalizer. The totalizer decimal is not a dummy decimal and will scale the totalizer display accordingly. (i.e. if the tdec is set in the tenths position (1234567.8), 100 will be displayed as 100.0). The location of the decimal point allows for greater resolution of both the totalizer display and the pulse output. The pulse output advances at a rate dependent on the least significant digit of the totalizer. The totalizer decimal location is restricted to a maximum of 4 places (1234.5678). However, the number of totalizer decimal locations allowable is reduced with each decimal place added to the factor decimal. Press the ← key to move the decimal. Press the **E** key to enter the displayed decimal location.

Note: The selection of the factor decimal point limits the available selections for the number of decimal points available for the totalizer. This is automatic. Enter your selection of the Factor's decimal point before entering the totalizer decimal point to assure the proper selection of the totalizer decimal point has been made.

DEFINITIONS

(continued)

total DESC: (totalizer descriptor) This allows you to illuminate one of the available descriptors on the display (STD: GAL, LIT, FT3, M3 or "blank"; "D" option: GAL, BBL, MCF, M3, "blank"). Press the ↑ key to select the descriptor. Press the **E** key to enter the selected descriptor.

SCALE: (ratemeter scaling) Sets the timebase for the rate readout. Choose rate per hour (HrS), minutes (MIN) or seconds (SEC). (Days will appear on units ordered with the "D" (rate per day) option.) The scale setting is shown on the main (upper) display. Press the ↑ key to step to the desired choice. Press the **E** key to enter the displayed scale setting.
Note: A rate descriptor corresponding to the above choice will be illuminated on the display.

DECLOC: (ratemeter decimal location) Sets the decimal location for the ratemeter information. The ratemeter decimal is not a dummy decimal and will scale the rate display accordingly. (i.e. if the r decloc is set in the tenths position (123.4), 100 will be displayed as 100.0). The ratemeter decimal location is restricted to a maximum of 4 places (.1234). However, the number of ratemeter decimal locations allowable is reduced with each decimal place added to the factor decimal. Press the ← key to move the decimal. Press the **E** key to enter the displayed decimal location.
Note: The flow rate indicator will flash "99999" if the computed flow rate exceeds the 99999 display capability of the indicator. Choose a new decimal point location to avoid this.

NOR # NORMALIZING FACTOR - Normalizes (averages or dampens) the flow rate data being received. Enter a value from 0 to 9. Higher settings provide more normalizing (averaging) for a more stable display. Derived from the equation:

$$\frac{(\text{Old Data} \times \text{"NOR"} + \text{New Data})}{(\text{"NOR"} + 1)}$$

DELAY: (delay) Sets the amount of time (0.1 to 99.9 seconds) that the unit will "look" for valid input data. If pulses are not detected within this "window", the rate will display 0. The display will update once every second as long as the unit receives valid data within a second. Some internal mathematics may delay this update. Press the ↑ key to increment each digit. Press the ← key to step to the next digit to the left. Press the **E** key to enter the displayed delay value.

out Lo: (out low) Sets the low setting for the 4-20 mA analog output. Key in the low rate value at which the unit will output 4mA. Press the ↑ key to increment each digit. Press the ← key to step to the next digit to the left. Press the **E** key to enter the displayed out lo value.

out Hi: (out high) Sets the high setting for the 4-20 mA analog output. Key in the high rate value at which the unit will output 20 mA. Press the ↑ key to increment each digit. Press the ← key to step to the next digit to the left. Press the **E** key to enter the displayed out hi value.

PULSE: (pulse out scaling) This allows the unit to output a pulse for each least significant total count divided by the selected divider. The pulse out can be divided by 1 (d 1), 10 (d 10), 100 (d 100), or turned off (OFF). With the divider set at 1, the unit will give a pulse out for every increment of the LSD displayed.

Note: For maximum battery life, turn the pulse output off when pulse output is not used.

Selecting the proper pulse output divider may be needed so that the pulse output does not exceed the maximum rate of the pulse output. If the pulse output pulses too quickly a flashing display will result. Pressing the "M" key will result in a display of an error message "E PULSE". Press the "E" key to return to the run mode.

PULSEW: (pulse width) Sets the pulse width of the pulse output. Selections are: 0.5 (1Hz), 0.25 (2Hz), 0.125 (4Hz) or 0.0625 (8Hz). This menu item is skipped if PULSE is turned off.

BAUDRATE: (baud rate) Sets the baud rate for the serial communication.

PARITY: (parity) Sets the parity for the serial communication.

LOCKCODE: (lock code) Sets the 5 digit lock code to be entered when the unit prompts Enter CODE. This allows the user to gain access to the menu when the unit is locked. Press the ↑ key to increment each digit. Press the ← key to step to the next digit to the left. Press the **E** key to enter the displayed code.

Record this number for later use!

LOCK CODE: _____

LOCKUNIT: (lock unit) Sets the panel lock ON or OFF. Press the ↑ key to select On or OFF. Press the **E** key to enter the displayed selection.

PROGRAMMING FLOWCHART

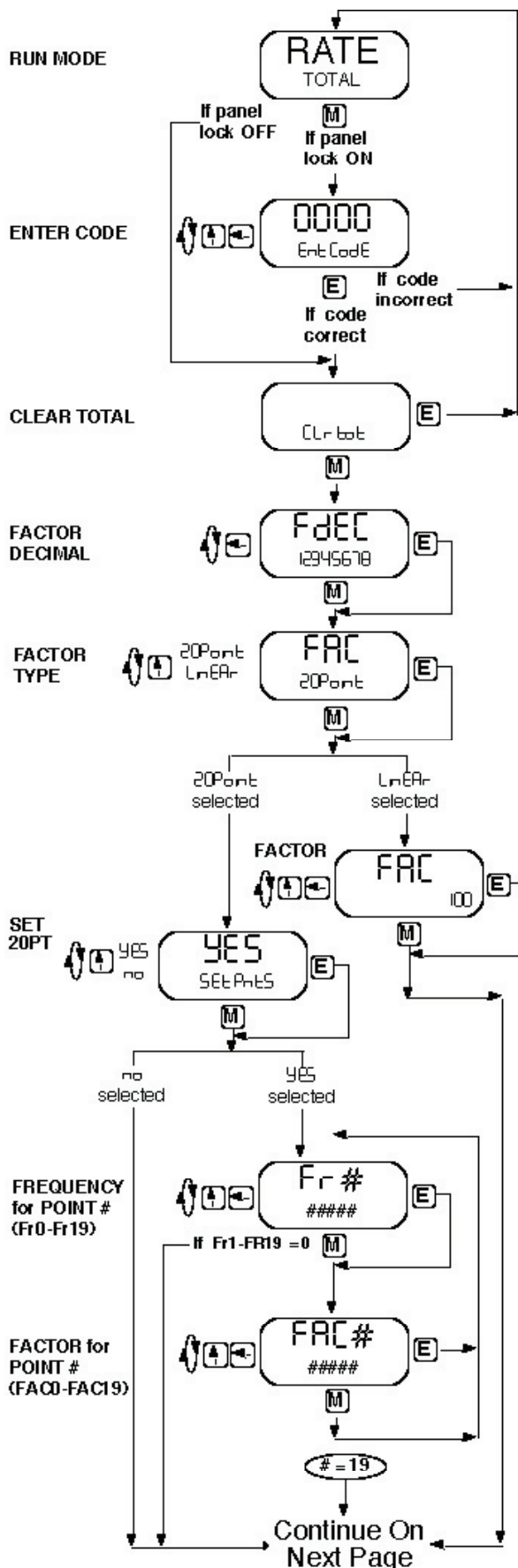

Press the **M** key to enter the programming menu.

If the panel lock is on, you must enter the 4 digit lock code to gain access to the menu.

Press the **↑** key to increment each individual digit of the code.

Press the **→** key to advance to the next digit.

Press the **E** key to enter the displayed code.

If the code is correct, display advances to "Clr tot", if not, display returns to run mode

Press the **E** key to clear the totalizer and return to the programming menu.

Press the **M** key to skip and go to next menu item.

Press the **←** key to step the factor decimal to the desired location.

Press the **E** key to enter the displayed decimal location.

Press the **M** key to skip and keep the existing location

NOTE: For best performance and resolution choose as many decimal places as possible in the K-Factor. Example: Enter a K-Factor of 1 as 1.000.

Press the **↑** key to choose factor type (20Point or LINEAR).

Press the **E** key to enter the displayed factor type.

Press the **M** key to skip and keep the existing factor type.

The FAC prompt will only appear if LINEAR is selected or if the unit was ordered without the 20 point linearization option.

Press the **↑** key to increment each individual digit of the factor.

Press the **→** key to advance to the next digit.

Press the **E** key to enter the displayed factor.

Press the **M** key to skip and keep the existing factor.

The SET PntS prompt will only appear if 20Point is selected. This allows users to bypass the 20 point set up and keep the existing values.

Press the **↑** key to choose YES or NO.

Press the **E** key to enter the displayed selection.

Press the **M** key to skip (same as selecting NO).

Press the **↑** key to increment each individual digit of the frequency for point #.

Press the **→** key to advance to the next digit.

Press the **E** key to enter the displayed frequency.

Press the **M** key to skip and keep the existing frequency.

If 0 is entered, the display will advance to the next prompt (tdec).

NOTE: Frequency/factor point pairs must be entered in ascending order of frequency

Press the **↑** key to increment each individual digit of the factor for point #.

Press the **→** key to advance to the next digit.

Press the **E** key to enter the displayed factor.

Press the **M** key to skip and keep the existing factor.

If 0 is entered, the display will advance to the next prompt (tdec).

PROGRAMMING FLOWCHART

(continued)

Continued From Previous Page

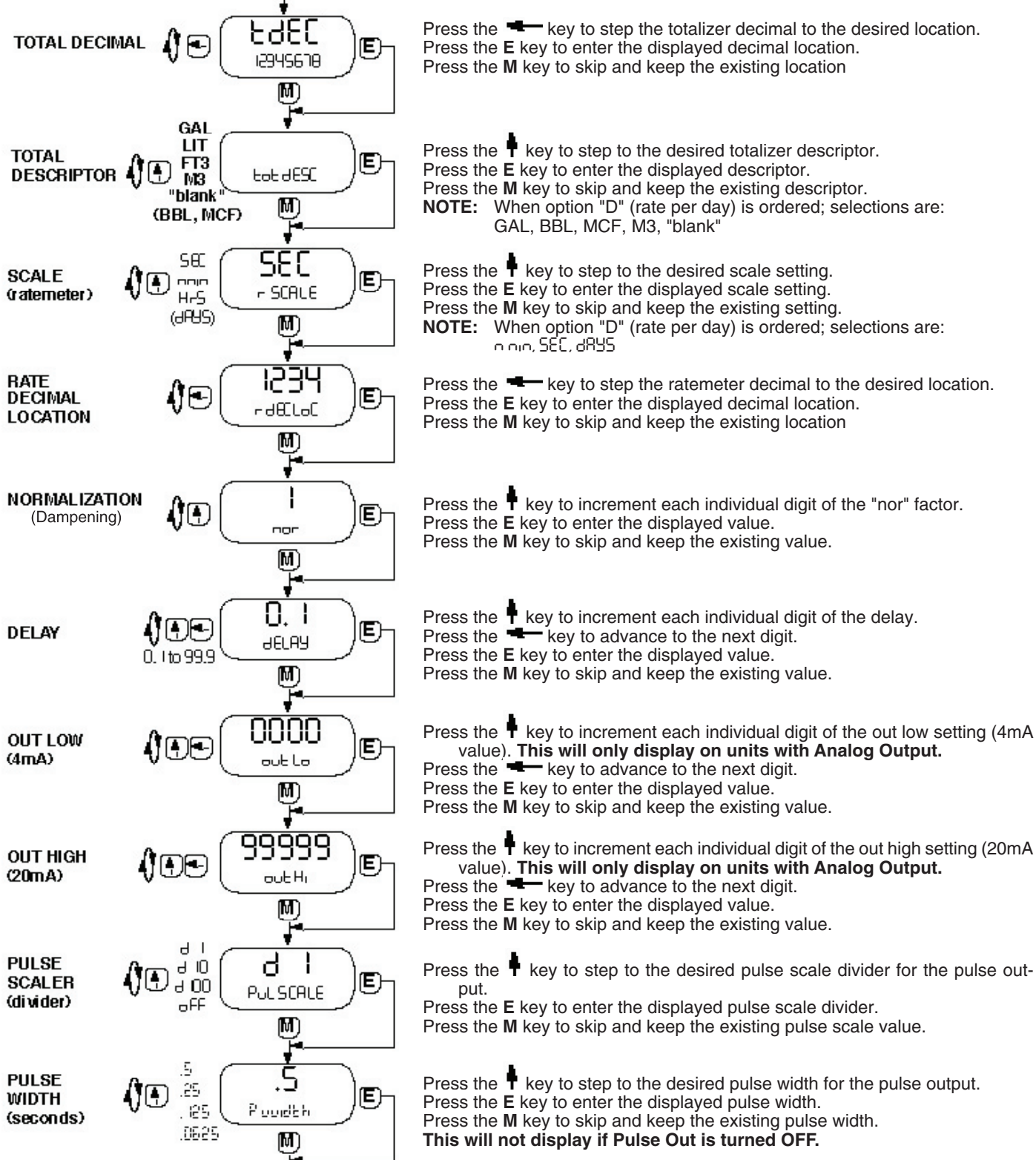

Continue On Next Page

PROGRAMMING FLOWCHART
(continued)

Continued From Previous Page

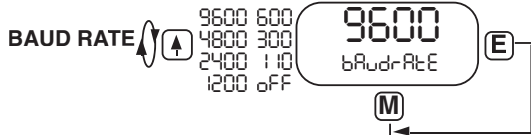

Press the key to select the desired baud rate.
Press the **E** key to enter the displayed choice.
Press the **M** key to skip and keep the existing choice.



Press the key to select the desired parity.
Press the **E** key to enter the displayed choice.
Press the **M** key to skip and keep the existing choice.



Press the key to increment each individual digit of the lock code.
Press the key to advance to the next digit.
Press the **E** key to enter the displayed value.
Press the **M** key to skip and keep the existing value.

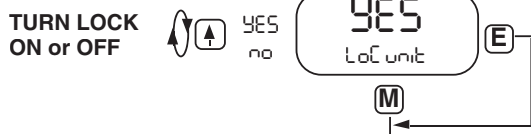

Press the key to step to the desired lock setting.
Press the **E** key to enter the displayed lock setting.
Press the **M** key to skip and keep the existing setting.

RUN MODE

RS485 Wiring

RS-485 Terminals

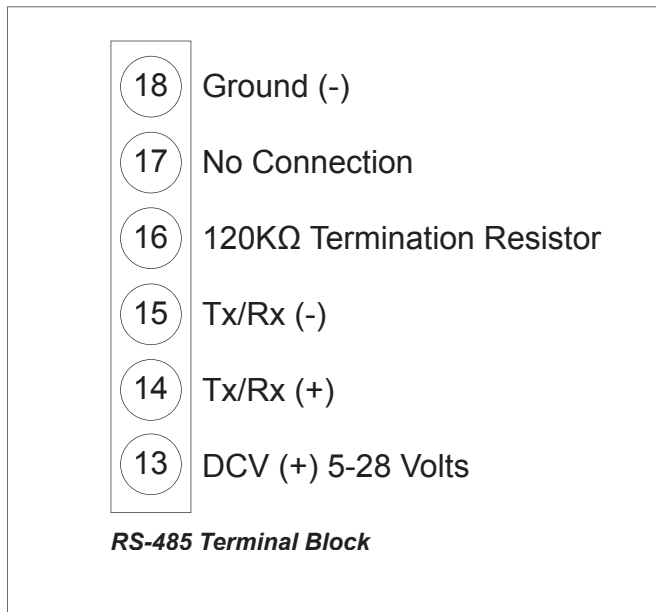

CA-285 Terminals

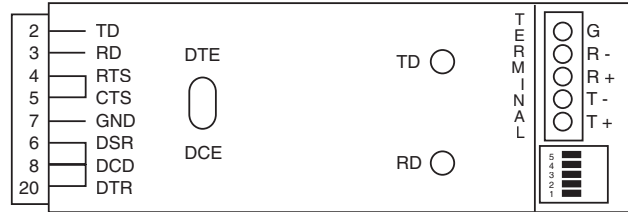

Switch Settings

Switch	Setting
1	ON
2	OFF
3	OFF
4	ON
5	OFF

Typical Hookup

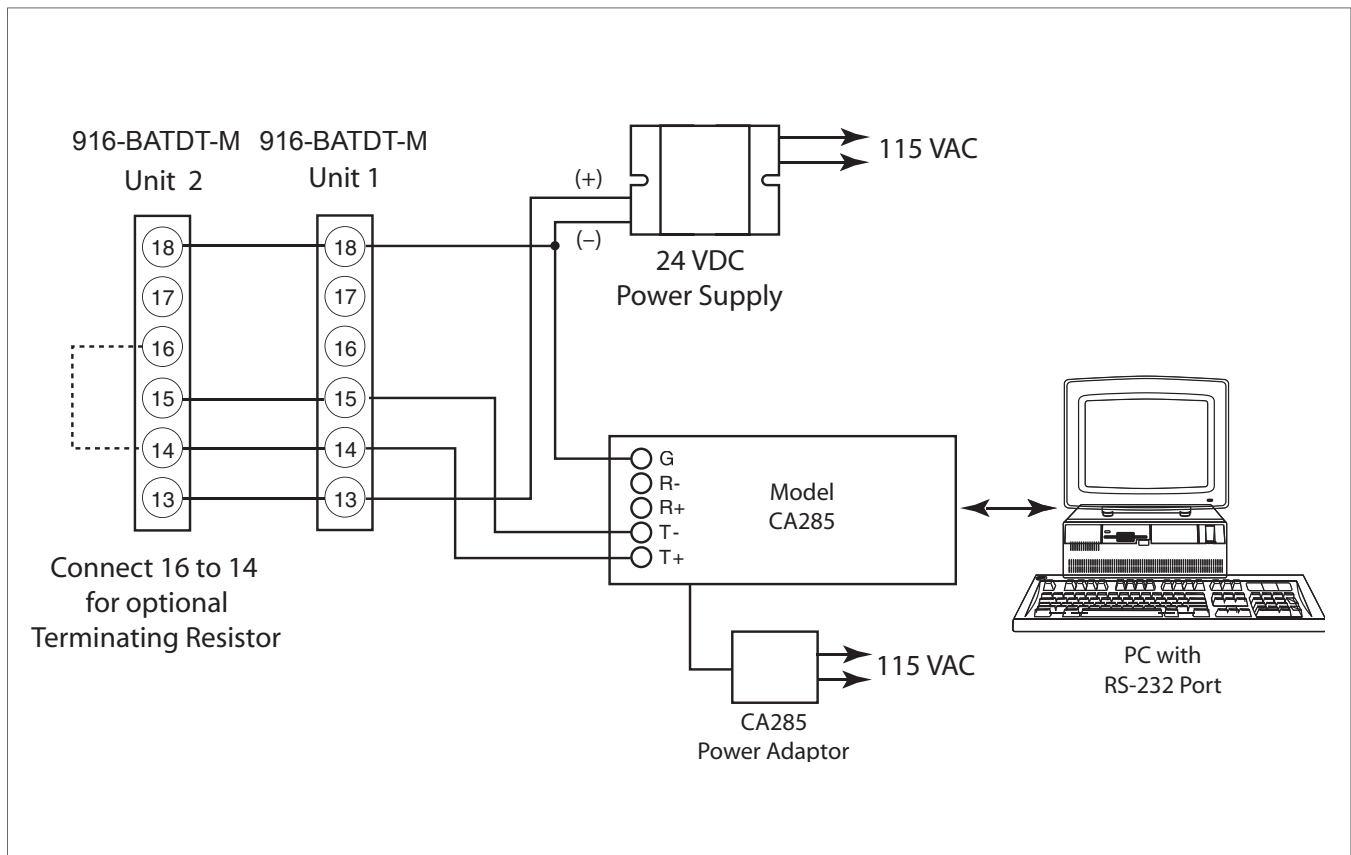

DEFINITIONS

SRU E tot RL: (Save Total) Press the **E** key while the unit is running to save the total value. The display will show "SRU E tot RL" for a few seconds. This is a very useful "scratch pad" to save and restore total when replacing the battery(ies)

Ent Code: (enter code) This prompt will only appear if the panel lock is ON. Press the \uparrow key to increment each digit. Press the \leftarrow key to step to the next digit to the left. Press the **E** key to enter the 5 digit code. If the entered code is correct, the display will advance to the next menu prompt (CLR tot). If incorrect, the display will return to the run mode.

CLR tot: (clear total) Clears (resets) the totalizer. Press the **E** key to clear the total and return to the run mode. Press the **M** key to skip and advance to the next menu selection.

FDEC: (factor decimal) Sets the decimal location for the factor. This location is restricted to 3 places (99.999). The use of this decimal automatically limits the number of decimal locations allowable in the rate and total to acceptable ranges. Press the \leftarrow key to move the decimal. Press the **E** key to select the displayed decimal location.

NOTE: For best performance and resolution choose as many decimal places as possible in the K-Factor.

Example: Enter a K-Factor of 1 as 1.000.

FAC LinEAR/ 10POINT: (factor type) This prompt will only appear if the unit is ordered with the 10 point linearization option. The **10POINT** linearization selection is recommended for flow meters whose K-factors change with different flow rates. This selection allows users to enter up to 10 different frequencies with 10 corresponding K-factors for different flow rates. The **LinEAR** setting is used for flow meters whose output is linear over its' entire operating flow range. Press the \uparrow key to step to the desired choice. Press the **E** key to enter the displayed factor type.

no / YES Set PointS: (set 10 point?) This prompt allows the user to skip the 10 point setup routine. Select **YES** for initial setup or to change the present 10 point values. Select **no** to skip and keep the existing values.

FAC : (factor) This prompt appears on all units with linear inputs. The Factor is the number of pulses per unit volume for the flow sensor. The pulses/unit volume is implied by the totalizer descriptor when a descriptor is used. The implied units for the Factor are then as follows:

<u>Standard</u>	<u>"D" Option</u>
GAL pulses/gallon	GAL pulses/gallon
LIT pulses/liter	BBL pulses/BBL
FT3 pulses/ft ³	MCF pulses/MCF
M3 pulses/M3	M3 pulses/M3

Factors from 0.0001 to 99999999 may be used. A "0" value for the factor is not allowed and the unit will default to "1" in LSD if a "0" entry is attempted. The factor is displayed on the subsidiary (lower) display. Press the \uparrow key to increment each digit. Press the \leftarrow key to step to the next digit to the left. Press the **E** key to enter the displayed factor.

Fr# : (frequency for point #) This prompt will only appear when 10 point selected. It sets the frequency for each of the 10 points (#). Press the \uparrow key to increment each digit. Press the \leftarrow key to step to the next digit to the left. Press the **E** key to enter the desired frequency for point #.

FAC# : (factor for point #) This prompt will only appear when 10 point selected. It sets the factor for each of the 10 points (#). Press the \uparrow key to increment each digit. Press the \leftarrow key to step to the next digit to the left. Press the **E** key to enter the desired factor for point #.

NOTE: The display will advance to the next point (Fr#) after each entry of the Fr & Fac until all 10 points are complete. entering a 0 in the Fr or fac setting will advance the display to the next menu prompt (tdec).

DEFINITIONS

(continued)

tDEC: (totalizer decimal) Sets the decimal location for the totalizer. The totalizer decimal is not a dummy decimal and will scale the totalizer display accordingly. (i.e. if the tdec is set in the tenths position (1234567.8), 100 will be displayed as 100.0). The location of the decimal point allows for greater resolution of both the totalizer display and the pulse output. The pulse output advances at a rate dependent on the least significant digit of the totalizer. The totalizer decimal location is restricted to a maximum of 4 places (1234.5678). However, the number of totalizer decimal locations allowable is reduced with each decimal place added to the factor decimal. Press the ← key to move the decimal. Press the **E** key to enter the displayed decimal location.

Note: The selection of the factor decimal point limits the available selections for the number of decimal points available for the totalizer. This is automatic. Enter your selection of the Factor's decimal point before entering the totalizer decimal point to assure the proper selection of the totalizer decimal point has been made.

tDESC: (totalizer descriptor) This allows you to illuminate one of the available descriptors on the display (STD: GAL, LIT, FT3, M3 or "blank"; "D" option: GAL, BBL, MCF, M3, "blank"). Press the ↑ key to select the descriptor. Press the **E** key to enter the selected descriptor.

rSCALE: (ratemeter scaling) Sets the timebase for the rate readout. Choose rate per hour (HrS), minutes (MIN) or seconds (SEC). (Days will appear on units ordered with the "D" (rate per day) option.) The scale setting is shown on the main (upper) display. Press the ↑ key to step to the desired choice. Press the **E** key to enter the displayed scale setting.

Note: A rate descriptor corresponding to the above choice will be illuminated on the display.

rDECLOC: (ratemeter decimal location) Sets the decimal location for the ratemeter information. The ratemeter decimal is not a dummy decimal and will scale the rate display accordingly. (i.e. if the r decloc is set in the tenths position (123.4), 100 will be displayed as 100.0). The ratemeter decimal location is restricted to a maximum of 4 places (.1234). However, the number of ratemeter decimal locations allowable is reduced with each decimal place added to the factor decimal. Press the ← key to move the decimal. Press the **E** key to enter the displayed decimal location.

Note: The flow rate indicator will flash "99999" if the computed flow rate exceeds the 99999 display capability of the indicator. Choose a new decimal point location to avoid this.

NOR # NORMALIZING FACTOR - Normalizes (averages or dampens) the flow rate data being received. Enter a value from 0 to 9. Higher settings provide more normalizing (averaging) for a more stable display. Derived from the equation:

$$\frac{(\text{Old Data} \times \text{"NOR"} + \text{New Data})}{(\text{"NOR"} + 1)}$$

DELAY: (delay) Sets the amount of time (0.1 to 99.9 seconds) that the unit will "look" for valid input data. If pulses are not detected within this "window", the rate will display 0. The display will update once every second as long as the unit receives valid data within a second. Some internal mathematics may delay this update. Press the ↑ key to increment each digit. Press the ← key to step to the next digit to the left. Press the **E** key to enter the displayed delay value.

out Lo: (out low) Sets the low setting for the 4-20 mA analog output. Key in the low rate value at which the unit will output 4mA. Press the ↑ key to increment each digit. Press the ← key to step to the next digit to the left. Press the **E** key to enter the displayed out lo value.

out Hi: (out high) Sets the high setting for the 4-20 mA analog output. Key in the high rate value at which the unit will output 20 mA. Press the ↑ key to increment each digit. Press the ← key to step to the next digit to the left. Press the **E** key to enter the displayed out hi value.

DEFINITIONS

(continued)

PULSARLE: (pulse out scaling) This allows the unit to output a pulse for each least significant total count divided by the selected divider. The pulse out can be divided by 1 (1), 10 (10), 100 (100), or turned off (OFF). With the divider set at 1, the unit will give a pulse out for every increment of the LSD displayed.

Note: For maximum battery life, turn the pulse output off when pulse output is not used.

Selecting the proper pulse output divider may be needed so that the pulse output does not exceed the maximum rate of the pulse output. If the pulse output pulses too quickly a flashing display will result. Pressing the "M" key will result in a display of an error message "E PULSE". Press the "E" key to return to the run mode.

PULSARLE: (pulse width) Sets the pulse width of the pulse output. Selections are: 0.5 (1Hz), 0.25 (2Hz), 0.125 (4Hz) or 0.0625 (8Hz). This menu item is skipped if PULSARLE is turned off.

ADDRESS: (address) Sets the address of the device from 1 to 247 for Modbus network.

BAUDRATE: (baud rate) Sets the baud rate for the serial communication.

PARITY: (parity) Sets the parity for the serial communication.

STOPBITS: (stop bits) Sets the number of stop bits for the serial communication. This menu item is skipped if Parity is nonE.

TRANSMISSION DELAY: (transmission delay) A delay can be added between the time the BatRT receives a request and when it responds to it (Note: RS485 option)

DATE: (date) Sets the date for the real time clock. The format is MMDDYYYY.

TIME: (time) Sets the time for the real time clock. The format is HHMM .

LOG TIME: (log time) Sets the time of day that the data logger will record the total.

VIEW LOG: (view log) Prompts user to view data logger. Select YES to view or NO to skip. When YES is selected for VIEW LOG. The display will show the date of the last log in month and day format MMDD. Use the "E" or "M" keys to view previous logs.

LOG CLEAR: (log clear) Prompts user to clear the data logger. Select YES if you want to clear else select no.

LOCK CODE: (lock code) Sets the 5 digit lock code to be entered when the unit prompts Enter Code. This allows the user to gain access to the menu when the unit is locked. Press the ↑ key to increment each digit. Press the ← key to step to the next digit to the left. Press the E key to enter the displayed code.

Record this number for later use!

LOCK CODE: _____

LOCK UNIT: (lock unit) Sets the panel lock ON or OFF. Press the ↑ key to select On or OFF. Press the E key to enter the displayed selection.

PROGRAMMING FLOWCHART

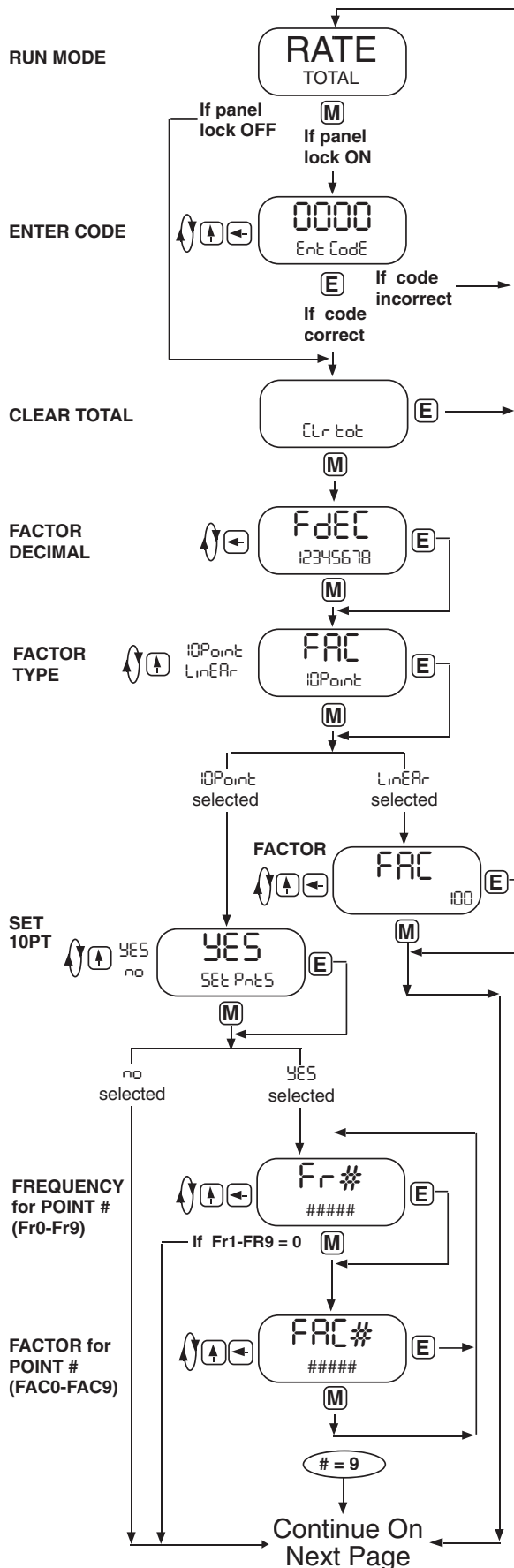

Press the **M** key to enter the programming menu.

If the panel lock is on, you must enter the 4 digit lock code to gain access to the menu.

Press the **↑** key to increment each individual digit of the code.

Press the **→** key to advance to the next digit.

Press the **E** key to enter the displayed code.

If the code is correct, display advances to "Clr Tot", if not, display returns to run mode

Press the **E** key to clear the totalizer and return to the programming menu.

Press the **M** key to skip and go to next menu item.

Press the **→** key to step the factor decimal to the desired location.

Press the **E** key to enter the displayed decimal location.

Press the **M** key to skip and keep the existing location

NOTE: For best performance and resolution choose as many decimal places as possible in the K-Factor. Example: Enter a K-Factor of 1 as 1.000.

Press the **↑** key to choose factor type (**10Point** or **LinERr**).

Press the **E** key to enter the displayed factor type.

Press the **M** key to skip and keep the existing factor type.

The **FAC** prompt will only appear if **LinERr** is selected or if the unit was ordered without the 10 point linearization option.

Press the **↑** key to increment each individual digit of the factor.

Press the **→** key to advance to the next digit.

Press the **E** key to enter the displayed factor.

Press the **M** key to skip and keep the existing factor.

The **SEt PntS** prompt will only appear if **10Point** is selected. This allows users to bypass the 10 point set up and keep the existing values.

Press the **↑** key to choose YES or NO.

Press the **E** key to enter the displayed selection.

Press the **M** key to skip (same as selecting NO).

Press the **↑** key to increment each individual digit of the frequency for point #.

Press the **→** key to advance to the next digit.

Press the **E** key to enter the displayed frequency.

Press the **M** key to skip and keep the existing frequency.

If 0 is entered, the display will advance to the next prompt (tdec).

NOTE: Frequency/factor point pairs must be entered in ascending order of frequency

Press the **↑** key to increment each individual digit of the factor for point #.

Press the **→** key to advance to the next digit.

Press the **E** key to enter the displayed factor.

Press the **M** key to skip and keep the existing factor.

If 0 is entered, the display will advance to the next prompt (tdec).

PROGRAMMING FLOWCHART

(continued)

Continued From Previous Page

TOTAL DECIMAL

The screen displays 'totDEC' and '12345678'.

Press the key to step the totalizer decimal to the desired location.
Press the **E** key to enter the displayed decimal location.
Press the **M** key to skip and keep the existing location

TOTAL DESCRIPTOR

The screen displays 'tot dESC' and 'GAL LIT FT3 M3 "blank" (BBL, MCF)'.

Press the key to step to the desired totalizer descriptor.
Press the **E** key to enter the displayed descriptor.
Press the **M** key to skip and keep the existing descriptor.
NOTE: When option "D" (rate per day) is ordered; selections are: GAL, BBL, MCF, M3, "blank"

SCALE (ratemeter)

The screen displays 'SEC' and 'SCALE'. Below the screen are options: 'SEC', 'nor', 'Hr-S', '(dAYS)'.

Press the key to step to the desired scale setting.
Press the **E** key to enter the displayed scale setting.
Press the **M** key to skip and keep the existing setting.
NOTE: When option "D" (rate per day) is ordered; selections are: nor, Hr-S, dAYS

RATE DECIMAL LOCATION

The screen displays '1234' and 'dECLoC'.

Press the key to step the ratemeter decimal to the desired location.
Press the **E** key to enter the displayed decimal location.
Press the **M** key to skip and keep the existing location

NORMALIZATION

The screen displays '1' and 'nor'.

Press the key to increment each individual digit of the "nor" factor.
Press the **E** key to enter the displayed value.
Press the **M** key to skip and keep the existing value.

DELAY (Dampening)

The screen displays '0.1' and 'dELAY'. Below the screen are options: '0.1 to 99.9'.

Press the key to increment each individual digit of the delay.
Press the key to advance to the next digit.
Press the **E** key to enter the displayed value.
Press the **M** key to skip and keep the existing value.

OUT LOW (4mA)

The screen displays '0000' and 'out Lo'.

Press the key to increment each individual digit of the out low setting (4mA value). **This will only display on units with Analog Output.**
Press the key to advance to the next digit.
Press the **E** key to enter the displayed value.
Press the **M** key to skip and keep the existing value.

OUT HIGH (20mA)

The screen displays '99999' and 'out Hi'.

Press the key to increment each individual digit of the out high setting (20mA value). **This will only display on units with Analog Output.**
Press the key to advance to the next digit.
Press the **E** key to enter the displayed value.
Press the **M** key to skip and keep the existing value.

PULSE SCALER (divider)

The screen displays 'd 1' and 'PUL SCALE'. Below the screen are options: 'd 1', 'd 10', 'd 100', 'off'.

Press the key to step to the desired pulse scale divider for the pulse output.
Press the **E** key to enter the displayed pulse scale divider.
Press the **M** key to skip and keep the existing pulse scale value.

PULSE WIDTH (seconds)

The screen displays '.5' and 'Pwidth'. Below the screen are options: '.5', '.25', '.125', '.0625'.

Press the key to step to the desired pulse width for the pulse output.
Press the **E** key to enter the displayed pulse width.
Press the **M** key to skip and keep the existing pulse width.
This will not display if Pulse Out is turned OFF.

Continue On Next Page

PROGRAMMING FLOWCHART

(continued)

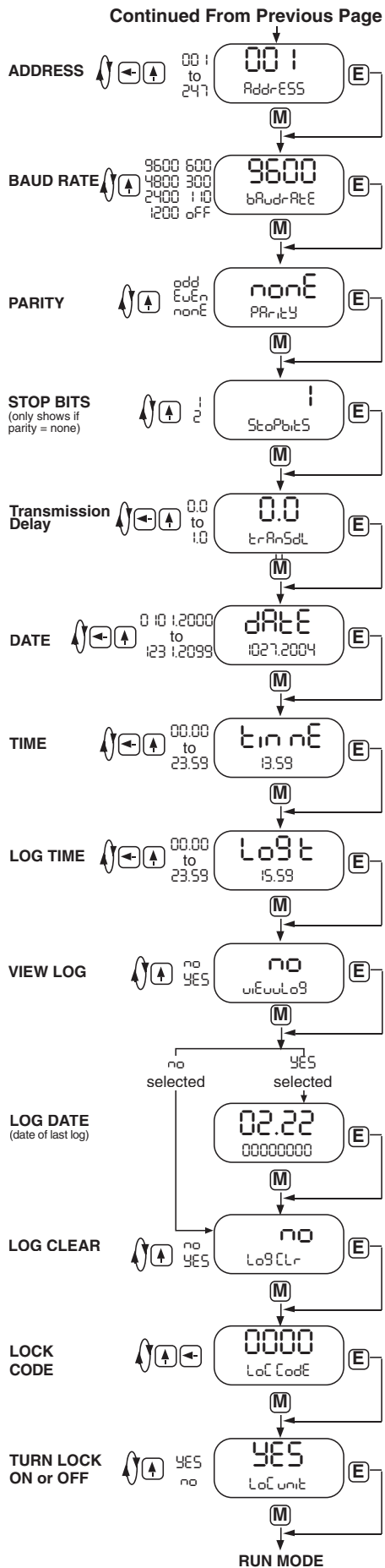

Press the **↑** key to increment each individual digit of the address.
 Press the **→** key to advance to the next digit.
 Press the **E** key to enter the displayed value.
 Press the **M** key to skip and keep the existing value.

Press the **↑** key to select the desired baud rate.
 Press the **E** key to enter the displayed choice.
 Press the **M** key to skip and keep the existing choice.

Press the **↑** key to select the desired parity.
 Press the **E** key to enter the displayed choice.
 Press the **M** key to skip and keep the existing choice.

Press the **↑** key to select the desired number of stop bits.
 Press the **E** key to enter the displayed choice.
 Press the **M** key to skip and keep the existing choice.
NOTE: Only appears if parity = none

Press the **↑** key to increment each individual digit of the trans. delay.
 Press the **→** key to advance to the next digit.
 Press the **E** key to enter the displayed value.
 Press the **M** key to skip and keep the existing value.

Press the **↑** key to increment each individual digit of the date.
 Press the **→** key to advance to the next digit.
 Press the **E** key to enter the displayed value.
 Press the **M** key to skip and keep the existing value.

Press the **↑** key to increment each individual digit of the time.
 Press the **→** key to advance to the next digit.
 Press the **E** key to enter the displayed value.
 Press the **M** key to skip and keep the existing value.

Press the **↑** key to increment each individual digit of the log time.
 Press the **→** key to advance to the next digit.
 Press the **E** key to enter the displayed value.
 Press the **M** key to skip and keep the existing value.

Press the **↑** key and select "yes" to view log. Select "no" to skip.
 Press the **E** key to enter the displayed choice.
 Press the **M** key to skip.

The date of last log will be shown in the format (MM.DD) if "yes" was selected above.
 Press **M** or **E** to view previous logs and exit when the end of datalog is reached.

Press the **↑** key and select "yes" to clear log. Select "no" to skip.
 Press the **E** key to enter the displayed choice.
 Press the **M** key to skip.

Press the **↑** key to increment each individual digit of the lock code.
 Press the **→** key to advance to the next digit.
 Press the **E** key to enter the displayed value.
 Press the **M** key to skip and keep the existing value.

Press the **↑** key to step to the desired lock setting.
 Press the **E** key to enter the displayed lock setting.
 Press the **M** key to skip and keep the existing setting.

KEYPAD OPERATION WITH S2 OPTION:

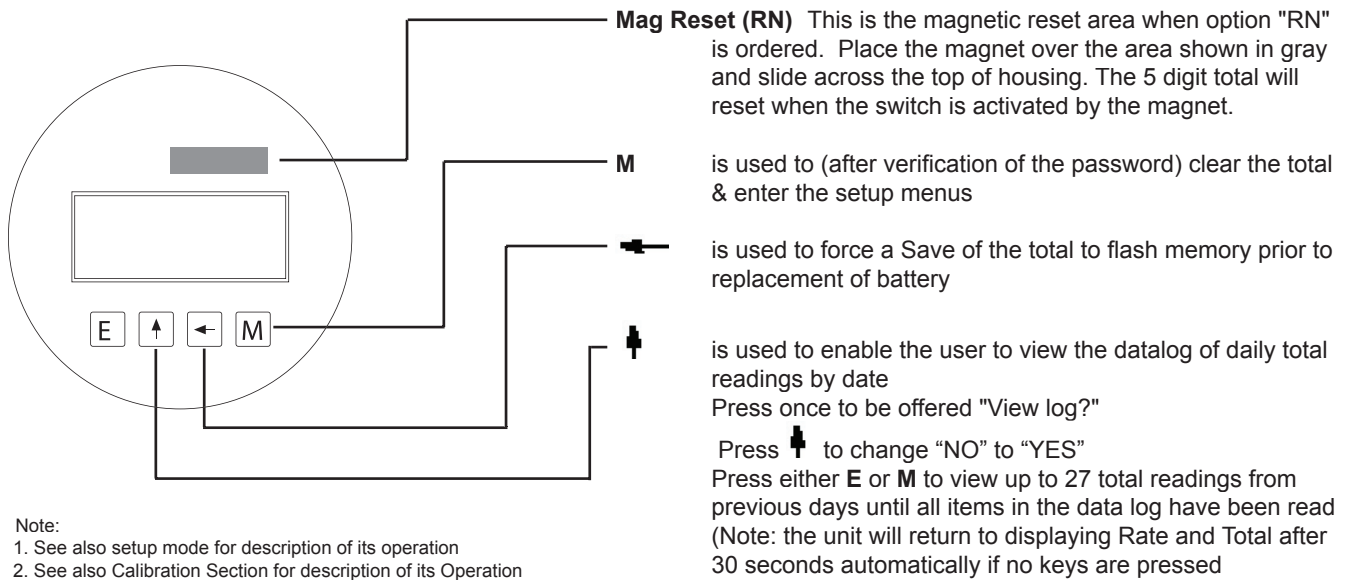

Modbus RTU Protocol

When the 916-BATDT-M is equipped with the Modbus option, the protocol it uses is the Modbus RTU protocol. This protocol defines a message structure that hosts and clients will recognize and use on the Modbus network over which they communicate. It describes the process a master device (PC compatible) uses to request access to another device (916-BATDT-M), how it will respond to requests from the other devices, and how errors will be detected and reported. It establishes a common format for the layout and contents of message fields. During communications on a Modbus RTU network, the protocol determines how each 916-BATDT-M will know its device address, recognize a message addressed to it, determine the kind of action to be taken, and extract any data or other information contained in the message. If a reply is required, the 916-BATDT-M will construct the reply message and send it using Modbus RTU protocol.

RTU Mode

The 916-BATDT-M with Modbus communications option supports the Modbus RTU (Remote Terminal Unit) mode only. The Modbus ASCII mode is not supported. The main advantage of the RTU mode is that its greater character density allows better data throughput than ASCII for the same baud rate. The Modbus RTU uses a Master-Slave Query-Response Cycle in which the 916-BATDT-M is the slave device.

Control Functions

The 916-BATDT-M with Modbus communications option supports the following function codes:

<u>CODE</u>	<u>NAME</u>	<u>DESCRIPTION</u>
01	Read Coil Status	Reads the status of a coil (ON or OFF)
03	Read Holding Registers	Reads the value in a holding register
05	Force Single Coil	Forces a single coil (0x reference) to either ON or OFF
06	Preset Single Register	Presets a value into a single holding register (4x reference)
15	Force Multiple Coil	Forces each coil (0x reference) in a sequence of coils to either ON or OFF
16	Preset Multiple Registers	Presets values into a sequence of holding registers (4x reference)

916-BATDT-M Communication Setup Menu

The setup menu allows Modbus RTU Protocol communications parameters of: Device ID, Baud Rate, and Parity to be selected to match the parameters of your Modbus network. Each 916-BATDT-M must have its own Device ID and the same Baud Rate and Parity setting.

Register & Coil Usage

Register Usage (each register is 2 bytes)

<u>Data</u>	<u>Register</u>	<u>Data Type</u>	<u>Access</u>
Volume Flow	Reg 40001 & 40002	Float	Read
Total	Reg 40003 & 40004	Float	Read
Linear K-Factor	Reg 40005 & 40006	Float	Read/Write
Frequency#0	Reg 40007 & 40008	Float	Read/Write
Factor#0	Reg 40009 & 40010	Float	Read/Write
Frequency#1	Reg 40011 & 40012	Float	Read/Write
Factor#1	Reg 40013 & 40014	Float	Read/Write
Frequency#2	Reg 40015 & 40016	Float	Read/Write
Factor#2	Reg 40017 & 40018	Float	Read/Write
Frequency#3	Reg 40019 & 40020	Float	Read/Write
Factor#3	Reg 40021 & 40022	Float	Read/Write
Frequency#4	Reg 40023 & 40024	Float	Read/Write
Factor#4	Reg 40025 & 40026	Float	Read/Write
Frequency#5	Reg 40027 & 40028	Float	Read/Write
Factor#5	Reg 40029 & 40030	Float	Read/Write
Frequency#6	Reg 40031 & 40032	Float	Read/Write
Factor#6	Reg 40033 & 40034	Float	Read/Write
Frequency#7	Reg 40035 & 40036	Float	Read/Write
Factor#7	Reg 40037 & 40038	Float	Read/Write
Frequency#8	Reg 40039 & 40040	Float	Read/Write
Factor#8	Reg 40041 & 40042	Float	Read/Write
Frequency#9	Reg 40043 & 40044	Float	Read/Write
Factor#9	Reg 40045 & 40046	Float	Read/Write
Rate Delay	Reg 40047 & 40048	Float	Read/Write
Analog Out Low	Reg 40049 & 40050	Float	Read/Write
Analog Out High	Reg 40051 & 40052	Float	Read/Write
Flow Total Log #0	Reg 40053 & 40054	Float	Read/Write
Flow Total Log #1	Reg 40055 & 40056	Float	Read/Write
Flow Total Log #2	Reg 40057 & 40058	Float	Read/Write
Flow Total Log #3	Reg 40059 & 40060	Float	Read/Write
Flow Total Log #4	Reg 40061 & 40062	Float	Read/Write
Flow Total Log #5	Reg 40063 & 40064	Float	Read/Write
Flow Total Log #6	Reg 40065 & 40066	Float	Read/Write
Flow Total Log #7	Reg 40067 & 40068	Float	Read/Write
Flow Total Log #8	Reg 40069 & 40070	Float	Read/Write
Flow Total Log #9	Reg 40071 & 40072	Float	Read/Write
Flow Total Log #10	Reg 40073 & 40074	Float	Read/Write
Flow Total Log #11	Reg 40075 & 40076	Float	Read/Write
Flow Total Log #12	Reg 40077 & 40078	Float	Read/Write
Flow Total Log #13	Reg 40079 & 40080	Float	Read/Write
Flow Total Log #14	Reg 40081 & 40082	Float	Read/Write
Flow Total Log #15	Reg 40083 & 40084	Float	Read/Write
Flow Total Log #16	Reg 40085 & 40086	Float	Read/Write
Flow Total Log #17	Reg 40087 & 40088	Float	Read/Write
Flow Total Log #18	Reg 40089 & 40090	Float	Read/Write
Flow Total Log #19	Reg 40091 & 40092	Float	Read/Write
Flow Total Log #20	Reg 40093 & 40094	Float	Read/Write
Flow Total Log #21	Reg 40095 & 40096	Float	Read/Write
Flow Total Log #22	Reg 40097 & 40098	Float	Read/Write
Flow Total Log #23	Reg 40099 & 40100	Float	Read/Write

Register & Coil Usage (continued)

<u>Data</u>	<u>Register</u>	<u>Data Type</u>	<u>Access</u>
Flow Total Log #24	Reg 40101 & 40102	Float	Read/Write
Flow Total Log #25	Reg 40103 & 40104	Float	Read/Write
Flow Total Log #26	Reg 40105 & 40106	Float	Read/Write
K-Factor Decimal Point	Reg 40133	Integer	Read/Write
K-Factor Algorithm	Reg 40134	Integer	Read/Write
Total Decimal Point	Reg 40135	Integer	Read/Write
Total Descriptors	Reg 40136	Integer	Read/Write
Rate Time scale	Reg 40137	Integer	Read/Write
Rate Decimal Point	Reg 40138	Integer	Read/Write
Rate Normalization	Reg 40139	Integer	Read/Write
Pulse Scale	Reg 40140	Integer	Read/Write
Device Address	Reg 40141	Integer	Read/Write
Baud Rate	Reg 40142	Integer	Read/Write
Parity	Reg 40143	Integer	Read/Write
Lock Code	Reg 40144 & 40145	Integer	Read/Write
Lock Unit	Reg 40146	Integer	Read/Write
Current Year (YYYY)	Reg 40147	Integer	Read/Write
Current Month (1-12)	Reg 40148	Integer	Read/Write
Current Day (1-31)	Reg 40149	Integer	Read/Write
Current Time Hr (00-23 24 Hr format)	Reg 40150	Integer	Read/Write
Current Time Min (00-59)	Reg 40151	Integer	Read/Write
Reading Time HH Hour (00-23)	Reg 40152	Integer	Read/Write
Reading Time MM Minute (00-59)	Reg 40153	Integer	Read/Write

NOTE: The Float data type follows the IEEE format for a 32 bit float.

COIL USAGE (each coil is 1 bit)

<u>Data</u>	<u>Coil</u>	<u>Data Type</u>	<u>Access</u>
Error-Rate Overflow	Coil 00001	bit	Read
Error-Pulse out Overflow	Coil 00002	bit	Read
Error-Total rollover	Coil 00003	bit	Read
Error-Flash problem	Coil 00004	bit	Read
Total Reset	Coil 00005	bit	Write
Clear Error	Coil 00006	bit	Write
Clear Data Log	Coil 00007	bit	Write