

AIR DRIVEN AIR PRESSURE AMPLIFIERS



SINGLE ACTING

3A-SS-2.5, 3A-SS-4



5A-DS-2



5A-DS-5

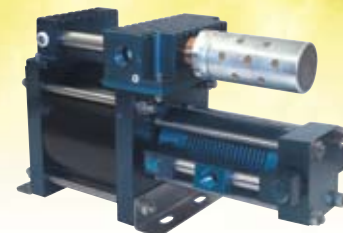

7A-DS-8

Hydraulics International air driven air pressure amplifiers operate using the principle of differential areas. Like any air tool, they operate from a single shop air connection for most applications. The air used for cycling exhausts through the muffler provided, or may be piped out of the area. The rest of the air is compressed to a higher pressure output. When output demand stops, the unit will stall in a force balanced condition consuming no power nor generating any heat. When output demand resumes, the unit automatically responds and cycles at the rate needed to meet that demand, up to the units capacity.

Output Flow Reaches Maximum as the amplifier's output pressure approaches the plant air input pressure. Output Flow Drops to Zero as the unit reaches theoretical stall. This value is estimated by multiplying input pressure x the last digit of the model number, e.g. model 5A-DS-5 with 100 PSI plant air input will stall at approximately 500 PSI, model 5A-DS-2 at approximately 200 PSI. In practice however, controlling the maximum pressure desired is usually done with an external control.

FEATURES • BENEFITS • APPLICATIONS

- **Compact:** installs off the floor, out of the way, in any position.
- **2 connections:** plant air in, amplified air out. (Pilot air connection is optional for start-stop control with a PCV valve or solenoid valve and pressure switch.)
- **Can replace a dedicated air compressor:** 10 HP size in a typical large plant spot requirement for 100 PSI when only 80 PSI is available. (Model 5A-DS-2)
- **Replace bottled nitrogen:** up to 700 PSI for air testing, lab or production. (Model 5A-DS-5 & 7A-DS-8)

DOUBLE ACTING

INSTALLATION AND CONTROLS

Although there are a number of options for controlling these units, a final recommendation will be based on how the high pressure output air is to be used. Perhaps the most common type of control is that similar to a conventional air compressor:

1. Amplify the air into a receiver tank, ASME coded if permanently mounted.
2. Provide a safety relief valve at maximum rated tank pressure.
3. Provide a pressure switch* set to stop the air amplifier unit at about 95% of safety relief valve setting.
4. Provide an air or gas regulator (reducing valve) on the tank output set at the minimum useable amplified air pressure for the application.

* The pressure switch need not be electrical. Instead, the HII series of PCV valves performs this function in one simple unit with no electrical input required.

TYPICAL APPLICATIONS FOR HIGHER AIR PRESSURE

- Valve actuators
- Air starters
- Bin vibrators
- Pneumatic drill motors
- Air clamps
- Air brakes
- Off road tires
- Pneumatic nailers, staplers, strapping machines
- Air/oil hoists
- Air presses

CHATSWORTH, CALIFORNIA, USA





TYPICAL APPLICATIONS

Model HIS-10001

(Also referenced as HIS-S5A-DS-2)

Description: The air pressure amplifier unit includes model 5A-DS-2 and it is a complete pneumatic system designed to provide double the available plant air pressure and momentary high flow. Tank is 15-gallon, 200-psi ASME code. The regulator on the tank outlet is provided to control the output pressure and flow. Tank relief valve is set at 200-psi.

Primary Applications: Assist air powered tools and machines in large plants with marginal central air pressure systems. Ideal to boost plant air pressure in tools for operation of automatic clamps, cylinders and other equipment.

Approximate Dimensions:

44" W x 32" D x 17" H



Model HIS-10002

(Also referenced as HIS-S5A-DS-5)

Description: This air pressure amplifier unit includes model 5A-DS-5 and it is a complete pneumatic system designed to provide 5x the available plant air pressure and momentary high flow. Tank is 5-gallon, 600-psi ASME code. The regulator on the tank outlet is provided to control the output pressure and flow. Tank relief valve is set at 600-psi.

Primary Applications: Pressure testing with plant compressed air up to 5x air in (up to 500-psi) with moderate flow or special devices. Ideal to boost plant air pressure in tools for operation of automatic clamps cylinders and other equipment.

Approximate Dimensions:

17" W x 15" D x 23" H



Model HIHP-10044 or HIHP-10045

(Also referenced as HIHP-S3A-SS-2.5 OR -4)

Description: This compact air pressure amplifier unit includes model 3A-SS-2.5 or 3A-SS-4 and it is a complete pneumatic system designed to provide 2.5x or 4x the available plant air pressure. Tank is approximately 1-gallon, D.O.T. code steel bottle. The inlet drive air regulator is provided to control the output pressure up to 675-psi.

Primary Applications: Assist smaller air powered tools and machines with marginal shop air pressure. Ideal for light duty, miscellaneous testing, and boosting into tight spaces.

Approximate Dimensions:

11" W x 11" D x 17" H



Model HIS-10003

Dual Air Amplifier System

(Also referenced as HIS-S5A-DS-2.5)

Description: This dual air amplifier system provides increased efficiency, flow and pressure. It consists of a model 5A-DS-2X piped into model 5A-DS-5X for a 2-stage configuration. Tank is 15-gallon, 400-psi ASME code. Tank pressure is controlled with a pilot cutoff valve (PVC), and is rated for a maximum pressure of 390-psi. This system is assembled, completely tested for maximum flow and pressure, and mounted on a rigid fork-lift-able steel frame with control panel.

Primary Applications: Pressure testing, purging, clamping with plant compressed air up 390-psi with high flow.

Approximate Dimensions:

30" W x 28" D x 43" H



BASIC DATA

Model No.	Wt. (lbs)	Boost DISPL. (IN ³ /Cycle)	MAXIMUM PRESS. (PSI)	
			Drive Section	Boost Section
3A-SS-2.5 ¹	7	2.66	150	400
3A-SS-4 ¹	7	1.60	150	675
5A-DS-2	36	202.8	150	300
5A-DS-5	30	24.1	150	1250
7A-DS-8	50	41.4	150	1250

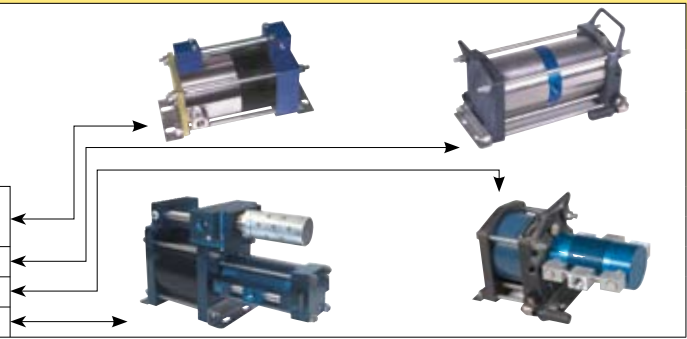

INSTALLATION

3A-SS-2.5 and 3A-SS-4

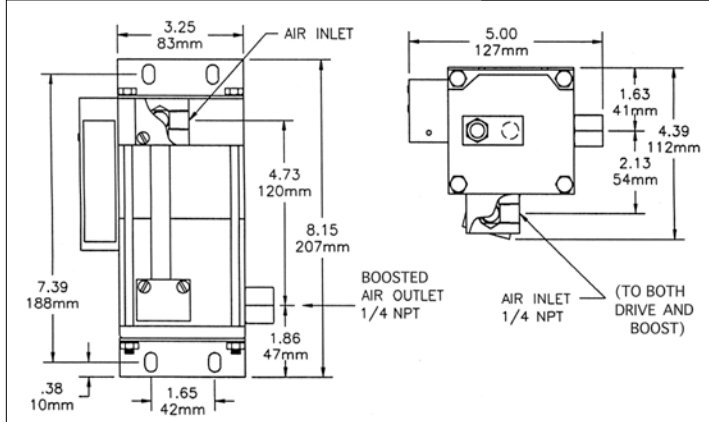

PERFORMANCE

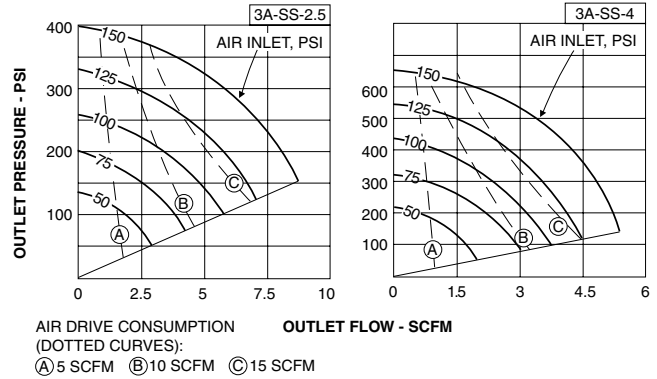

INSTALLATION

5A-DS-2

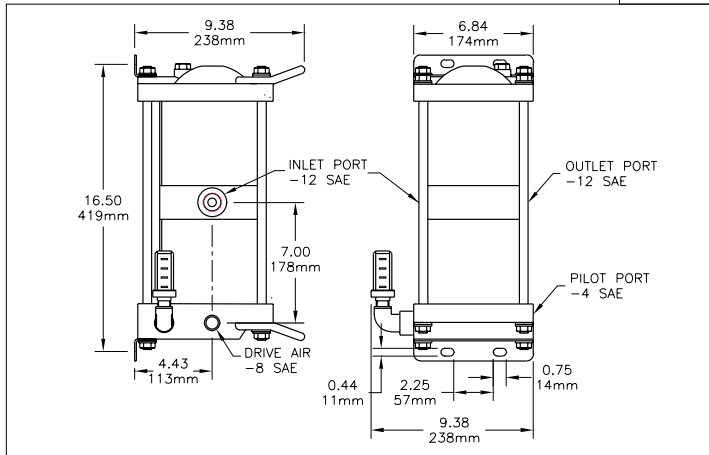

PERFORMANCE

5A-DS-2

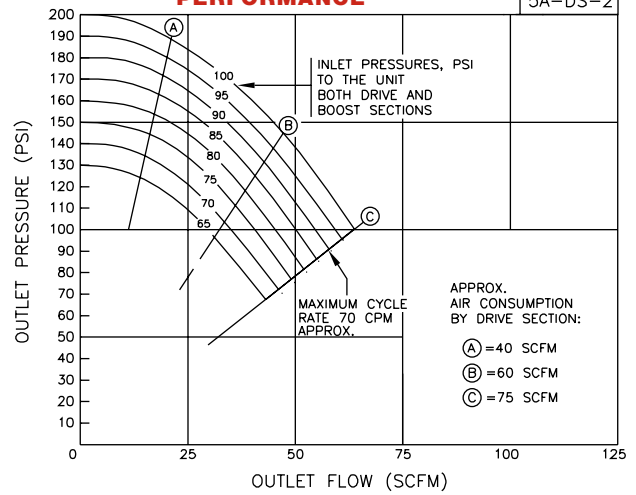

INSTALLATION

5A-DS-5

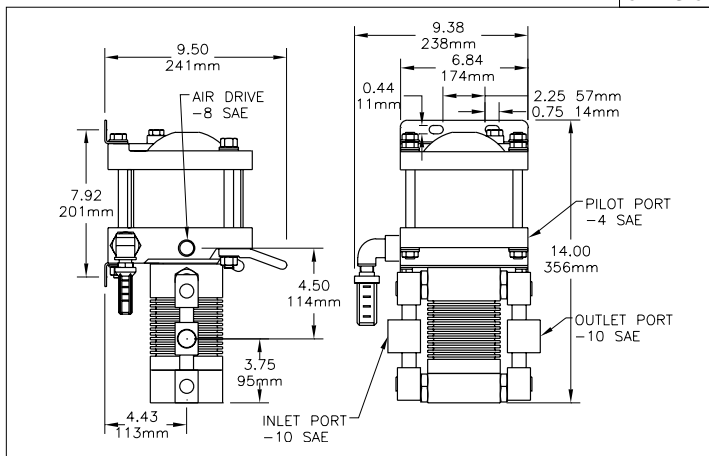

PERFORMANCE

5A-DS-5

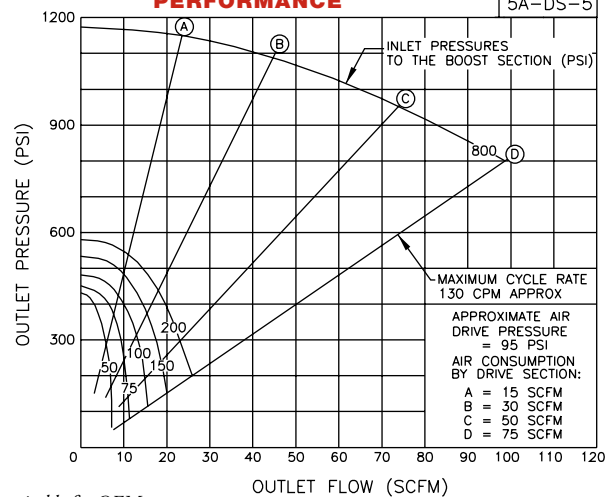

Note: ¹ The 3A Series is recommended for lower flow, intermittent duty and, due to its compact size, is suitable for OEM installations (with a small receiver) to ensure proper machine operation where the air supply may be marginal.



INSTALLATION

7A-DS-8

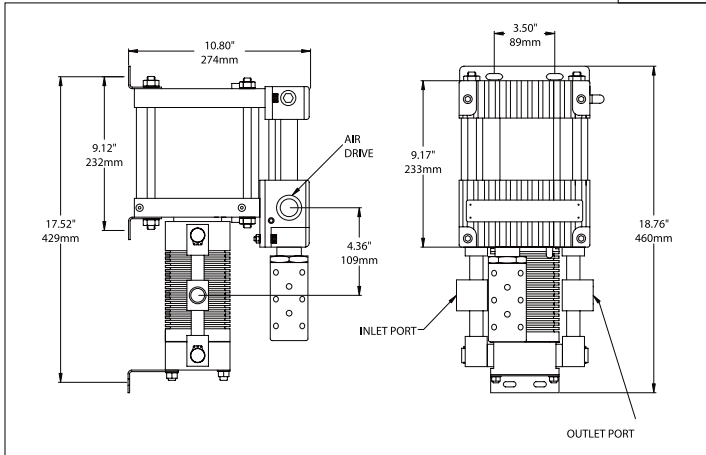

PERFORMANCE

7A-DS-8

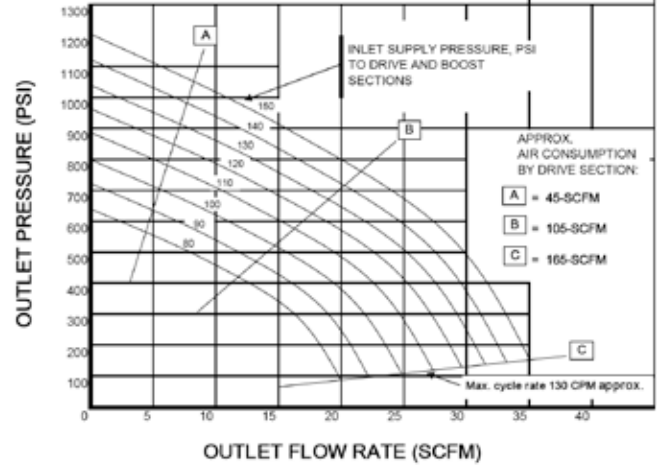

OTHER HII QUALITY PRODUCTS - Designed, sourced, and manufactured in the USA



AIR DRIVEN LIQUID PUMPS

- Self lubricating
- No electrical power needed
- Portable, lightweight and economical
- Wide range of models in 3", 5 3/4" and 7" drive sizes
- Pressures up to 80,000 PSI
- All models are rated for plain water or oil
- Ideal for OEM applications



AIR DRIVEN GAS BOOSTERS

- Airline lubrication not required
- Boosts pressure from 50 to 25,000 PSI
- Lightweight, 1-man portable
- Corrosion resistant including offshore environment
- Self-cooling using own exhaust air
- No electrical connections needed
- Wide range of models in single acting, double acting, two stage, and double air drive configuration

QUICK REFERENCE: INTERNATIONAL EQUIVALENTS

VOLUME

1 LITRE = 61 IN³ = .26 U.S. GAL
1 NM³ = 35.3 SCF

PRESSURE

1 BAR = 14.5 PSI = 1.02 Kg/cm² = 100 Kpa = .986 ABSOLUTE ATM
1 Mpa = 10 BAR = 1000 Kpa
1 ABSOLUTE ATM = 14.7 PSIA = 0 PSIG

WEIGHT

1 Kg = 2.2 LBS

LENGTH

1 IN = 25.4 mm

