

Key Features & Advantages of HCT-12 (Military 6,000 PSI Hydraulic Test Stands)

The key reasons why MRO Facility now requires 5,000 PSI Hydraulic Test Stand are as follows:

- 1) New generation military or commercial aircraft are fitted with better performance aircraft hydraulic components, which require higher test pressure and higher flow rate.
- 2) Each Hydraulic Independent System must be capable of delivering Flow rate of 25 GPM @ 3,000 PSI and 20 GPM @ 6,000 PSI or combined of 50 GPM @ 3,000 PSI or 40 GPM @ 6,000 PSI.
- 3) Dual Independent Hydraulic System will also be required as new generation aircraft component may require two independent hydraulic power supplies for its repair testing.

Current 3,000 PSI Hydraulic Test Stands like HCT-10 are no longer capable to support new generation aircraft components; as such we are offering our new replacement HCT-12.

6,000 PSI Hydraulic Test Stand from any OEM including HII can be used to carry out repair testing on any aircraft components whether fitted on military or commercial aircraft including helicopter.

Operator Safety & Ease of Operation (See Photos below)

Is the Test Sink Area for placing the UUT located on its Main Hydraulic Console (MHC) or located in a separate Area?

The Test Sink Area for HCT-12 is located on its MHC to provide ease of Operator Testing.

Where are the locations of all required Input & Output connections (hydraulic or pneumatic or electrical) or Sampling Ports for the UUT?

**UUT: Unit Under Test*

As for HCT-12, all its Input & Output connections (hydraulic or pneumatic or electrical) or Sampling Ports for the connecting to the UUT are located around the Test Sink Area providing ease of connection & repair testing by the Operator.

HCT-12 is installed with a transparent Protective Cover for the Test Sink Area, which ensure Operator's safety as the UUT & all its required Input & Output connections (Sampling Ports) are also being enclosed too. If any of the 6,000 PSI Hose is burst during testing, the Operator will not be injured.

Therefore the locations of Input & Output connections (Sampling Ports), Test Sink Area and UUT are extremely important safety consideration. Electrical Power Supply Cables for connection to UUT if too long or messy can cause electric shock to Operator as its can be easily damaged.

Annual Calibration

What are the components required to be removed from the 6,000 PSI Hydraulic Test Bench to be sent out for annual calibration? How many Gauges, Temperature Sensors, Pressure Sensors, Flow Transducers etc. are required to be removed?

How long to remove them and how long to fit them back? What is the total down time for 6,000 PSI Hydraulic Test Bench for each annual calibration?

As for HCT-12, there are no Gauges fitted. No need to remove any component as HCT-12 is designed to provide for calibration of these components at location, without requiring for their removal for annual calibration by using our Instrument Verification Set (IVS). An experience Operator will need about 30 mins to verify acceptable accuracy of built-in Instrument like Temperature or Pressure Sensors, Flow Transducers etc. without having to remove them for annual calibration.

Components

What is the percentage of components built in-house and how is obsolescence on critical components being taken care? How many years can Spares be guaranteed?

More than 90% including critical components like Flowmeters, Valves, Pressure Control Devices, Air Driven Gas Boosters or Liquid Pumps used on HCT-12 are built in-house by our Pumps Division & Flowmetrics Inc. ensuring spares supportability for more than 20 years.

Ease of Maintenance

How long to replace Filter Elements or any consumable parts and where are their locations?

As for HCT-12, Filter Elements or any consumable parts are easily accessible and does not require disconnecting fittings and/or interconnecting hydraulic lines.

Fault Diagnostic

Is there any fault diagnostic?

As for HCT-12, if a fault exists before system operation or a fault occurs during system operation, fault conditions will immediately report to HMI message field and an audible warning horn HRN is activated. All fault conditions are permanently stored to retentive memory of HMI computer, up to 200 fault conditions

Accuracy (see below photos of HMI Display Screen)

Is HCT-12 fitted with Gauges and what are their functions and accuracies?

HCT-12 is not fitted with Gauges. Any critical reading of Pressure, Flow Rate or Temperature is very accurately and digitally displayed on the HMI Display Screen.

Specifications Testing & Environmental Qualifications (see attached HCT-12 Specifications)

Is the 6,000 PSI Hydraulic Test Stand built to any stringent specification requirement testing?

HCT-12 has also been qualified to the most rigorous military requirement testing such as Environmental, Mobility, Electro Magnetic Interference, Reliability, Maintainability, Shock, Vibration, Sound Attenuation etc. as required by the US Government.

Reliability Demonstration Test

Has any Reliability Demonstration Test been carried out?

What is its expected MTBF (Mean Time Between Failure)?

As for HCT-12, its reliability test has been performed on the full range & capabilities of the MHC Pilot Production Unit (PPU) in accordance with MIL-HDBK-781A over 1000 hours (MTBF) without failures.

Production (<http://www.fbodaily.com/archive/2012/08-August/10-Aug-2012/FBO-02831090.htm>)

Is there any production of 6,000 PSI Hydraulic Test Stand at their facility? How many Units are in current production?

As for HCT-12, HII is currently in production of 80 Units for US Government & export market. Spares can be guaranteed for more than 20 years.

OPERATOR SAFETY & EASE OF OPERATIONS



HCT-12

All Displays, Mechanical / Touch Screen Controls, Test Sink Area, Sampling Ports (Hydraulic, Pneumatic & Electrical Power Supply) are located on Main Hydraulic Console (MHC).

The Operator only has to look in front without having to move locations providing ease of Operation's operation.

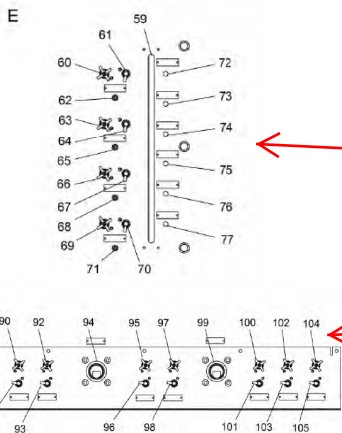

TEST SINK AREA

No messy Hoses or Cables from Sampling Ports hanging from one place to another location. All Sampling Ports are located inside the transparent Protective Cover of Test Sink Area providing Operator's safety.

SAMPLING PORTS

Hydraulic, Pneumatic & Electrical Supply

Located within Test Sink Area

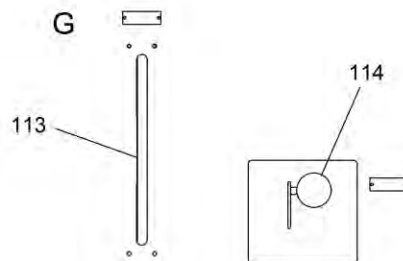
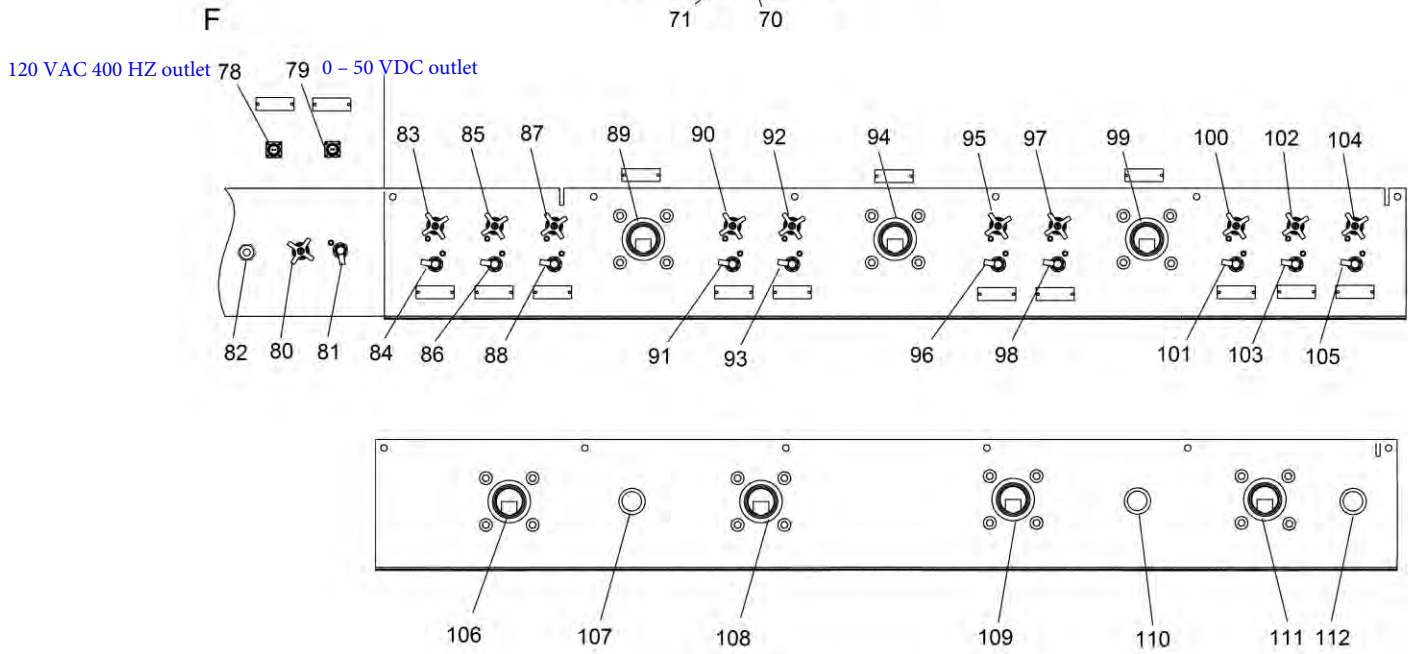
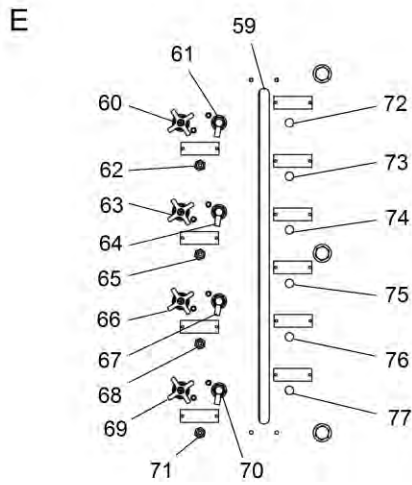

Test Sink Area

SAMPLING PORTS

Hydraulic, Pnuematic & Electrical Supply

Located within Test Sink Area

Table 2. MHC Controls and Indicators - Continued

FIG. 1 INDEX NO.	NOMENCLATURE	INITIAL POS.	REF DES	FUNCTION
56	CIRCUIT 2 BYPASS VALVE SV5	Fully CCW	SV5	Flow and pressure bypass valve.
57	CIRCUIT 2 CYCLING CIRCUIT SHUTOFF VALVE SV8	Fully CW	SV8	Cylinder cycling circuit shutoff.
58	CIRCUIT 2 SUPPLY PORT P2 SHUTOFF VALVE SV6	Fully CW	SV6	Supply port P2 shutoff.
59	Reservoir Level Indicator	1/2 to 3/4 full	LI1	Indicates fluid level of 55 gallon hydraulic reservoir.
60	CIRCUIT 1 SAMPLING PORT SUPPLY FILTER F1 valve	Fully CW	NV1	Sampling port shutoff valve.
61	CIRCUIT 1 SAMPLING PORT SUPPLY FILTER F1 port	Capped	SP1	Sampling port, POD compatible.
62	CIRCUIT 1 SAMPLING PORT SUPPLY FILTER F1	Capped	SP1A	Sampling port for collection bottle.
63	CIRCUIT 2 SAMPLING PORT SUPPLY FILTER F2 valve	Fully CW	NV2	Sampling port shutoff valve.
64	CIRCUIT 2 SAMPLING PORT SUPPLY FILTER F2 port	Capped	SP2	Sampling port, POD compatible.
65	CIRCUIT 2 SAMPLING PORT SUPPLY FILTER F2	Capped	SP2A	Sampling port for collection bottle.
66	RETURN CIRCUIT SAMPLING PORT RETURN FILTER F4 valve	Fully CW	NV3	Sampling port shutoff.
67	RETURN CIRCUIT SAMPLING PORT RETURN FILTER F4 port	Capped	SP3	Sampling port, POD compatible.
68	RETURN CIRCUIT SAMPLING PORT RETURN FILTER F4	Capped	SP3A	Sampling port for collection bottle.
69	LOW PRESS. CIRCUIT SAMPLING PORT SUPPLY FILTER F3 valve	Fully CW	NV4	Sampling port shutoff valve.
70	LOW PRESS. CIRCUIT SAMPLING PORT SUPPLY FILTER F3 port	Capped	SP4	Sampling port, POD compatible.
71	LOW PRESS. CIRCUIT SAMPLING PORT SUPPLY FILTER F3	Capped	SP4A	Sampling port for collection bottle.
72	0 – 150 PSI AUXILIARY GAUGE PT12	Capped	PT12	Auxiliary pressure transducer gauge inlet port, 0-150 PSI.
73	0 – 150 PSI AUXILIARY GAUGE PT13	Capped	PT13	Auxiliary pressure transducer gauge inlet port, 0-150 PSI.
74	0 – 600 PSI AUXILIARY GAUGE PT14	Capped	PT14	Auxiliary pressure transducer gauge inlet port, 0-600 PSI.

Table 2. MHC Controls and Indicators - Continued

FIG. 1 INDEX NO.	NOMENCLATURE	INITIAL POS.	REF DES	FUNCTION
75	0 – 600 PSI AUXILIARY GAUGE PT15	Capped	PT15	Auxiliary pressure transducer gauge inlet port, 0-600 PSI.
76	0 – 6000 PSI AUXILIARY GAUGE PT16	Capped	PT16	Auxiliary pressure transducer gauge inlet port, 0-6000 PSI.
77	0 – 6000 PSI AUXILIARY GAUGE PT17	Capped	PT17	Auxiliary pressure transducer gauge inlet port, 0-6000 PSI.
78	120 VAC 400 HZ outlet	-	CN7	Supplies AC voltage for testing of UUT.
79	0 – 50 VDC outlet	-	CN4	Supplies DC voltage for testing of UUT.
80	N2 SUPPLY PORT P7 XDUCER PT11 CALIBRATION PORT valve	Fully CCW	NV15	Isolates gas booster N ₂ supply pressure transducer PT11 for calibration.
81	N2 SUPPLY PORT P7 XDUCER PT11 CALIBRATION PORT	Capped	CP11	Gas booster N ₂ supply pressure transducer port for calibration.
82	PODS RETURN	Capped	-	Quick Disconnect (QD), allows direct connection of the Portable Oil Diagnostic System (PODS) for sample analyzing.
83	CIRC 1 SUPPLY PRESS XDUCER PT1 CALIBRATION PORT valve	Fully CCW	NV5	Isolation valve for supply pressure transducer PT1.
84	CIRC 1 SUPPLY PRESS XDUCER PT1 CALIBRATION PORT	Capped	CP1	Supply pressure port for Circuit 1 supply calibration.
85	CIRC 1 RETURN BACK PRESS XDUCER PT2 CALIBRATION PORT valve	Fully CCW	NV6	Back pressure transducer PT2 isolation valve used during calibration.
86	CIRC 1 RETURN BACK PRESS XDUCER PT2 CALIBRATION PORT	Capped	CP2	Back pressure calibration port.
87	CIRC 2 SUPPLY PRESS XDUCER PT3 CALIBRATION PORT valve	Fully CCW	NV7	Supply pressure transducer PT3 isolation valve used during calibration.
88	CIRC 2 SUPPLY PRESS XDUCER PT3 CALIBRATION PORT	Capped	CP3	Supply pressure port for Circuit 2 supply calibration.
89	RETURN PORT R1	Capped	R1	Circuit 1 return port
90	CIRC 2 CYCLING BACK PRESS XDUCER PT4 CALIBRATION PORT valve	Fully CCW	NV8	Cycling back pressure transducer PT4 isolation valve during calibration. Circuit 2
91	CIRC 2 CYCLING BACK PRESS XDUCER PT4 CALIBRATION PORT	Capped	CP4	Cycling back pressure.

Table 2. MHC Controls and Indicators - Continued

FIG. 1 INDEX NO.	NOMENCLATURE	INITIAL POS.	REF DES	FUNCTION
92	LOW PRESS CIRC PRESS XDUCER PT5 CALIBRATION PORT valve	Fully CCW	NV9	Low pressure circuit supply pressure transducer PT5 isolation valve used during calibration. Circuit 2
93	LOW PRESS CIRC PRESS XDUCER PT5 CALIBRATION PORT	Capped	CP5	Low pressure circuit supply.
94	FREE RETURN PORT R3	Capped	R3	Allows return of hydraulic fluid to reservoir with less than 5 PSI drop. Port can be used to fill the reservoir from a hydraulic servicing unit.
95	TEST BENCH AIR INLET PRESS XDUCER PT6 CALIBRATION PORT valve	Fully CCW	NV10	Shop air inlet pressure transducer PT6 isolation valve used during calibration.
96	TEST BENCH AIR INLET PRESS XDUCER PT6 CALIBRATION PORT	Capped	CP6	Air inlet pressure.
97	TEST BENCH N2 INLET PRESS XDUCER PT7 CALIBRATION PORT valve	Fully CCW	NV11	Nitrogen inlet pressure transducer PT7 isolation valve during calibration.
98	TEST BENCH N2 INLET PRESS XDUCER PT7 CALIBRATION PORT	Capped	CP7	Nitrogen inlet pressure.
99	RETURN PORT R2	Capped	R2	Circuit 2 return port.
100	HYDROSTATIC PUMP AIR INLET XDUCER PT8 CALIBRATION PORT shutoff valve	Fully CCW	NV12	Hydrostatic pump air inlet pressure transducer PT8 isolation valve during calibration.
101	HYDROSTATIC PUMP AIR INLET XDUCER PT8 CALIBRATION PORT	Capped	CP8	Hydrostatic pump air inlet pressure.
102	N2 BOOSTER AIR INLET XDUCER PT9 CALIBRATION PORT shutoff valve	Fully CCW	NV13	Gas booster air inlet pressure transducer PT9 isolation valve during calibration.
103	N2 BOOSTER AIR INLET XDUCER PT9 CALIBRATION PORT	Capped	CP9	Gas booster air inlet pressure port.
104	HYDROSTATIC SUPPLY PORT P8 XDUCER PT10 CALIBRATION PORT valve	Fully CCW	NV14	Hydrostatic pump supply pressure transducer PT10 isolation valve during calibration.
105	HYDROSTATIC SUPPLY PORT PXUCER PT10 CALIBRATION PORT	Capped	CP10	Hydrostatic supply pressure port.

Table 2. MHC Controls and Indicators - Continued

FIG. 1 INDEX NO.	NOMENCLATURE	INITIAL POS.	REF DES	FUNCTION
106	CIRCUIT 2 SUPPLY PORT P2	Capped	P2	Supply ports for Circuit 2.
107	LOW PRESS. CIRCUIT SUPPLY PORT P5	Capped	P5	Supply port for low pressure circuit.
108	CIRCUIT 2 CYCLING PORT P4	Capped	P4	Supply port for cycling test.
109	CIRCUIT 2 CYCLING PORT P3	Capped	P3	Supply port for cycling test.
110	NITROGEN CIRCUIT SUPPLY PORT P7	Capped	P7	Supply port for pneumatic (N ₂) circuit.
111	CIRCUIT 1 SUPPLY PORT P1	Capped	P1	Supply ports for Circuit 1.
112	HYDROSTATIC CIRCUIT SUPPLY PORT P6	Capped	P6	Supply port for hydrostatic circuit.
113	WASTE RESERVOIR LEVEL INDICATOR	1/2 or less	LI2	Indicates fluid level of 10 gallon waste hydraulic reservoir.
114	WASTE RESERVOIR DRAIN VALVE BV10	Handle vertical	BV10	Allows draining of 10 gallon waste hydraulic reservoir.
115	Main circuit breaker	OFF	CB1	Circuit breaker used for primary circuit protection.
116	Shield assembly	-	-	Protects operator from pressurized UUTs during testing of pumps and motors.
117	Remote EMERGENCY STOP	Out	E/S2	Immediate shutdown of HCTS operations.

HMI DISPLAY SCREEN

Pressure, Flowrate & Temperature etc

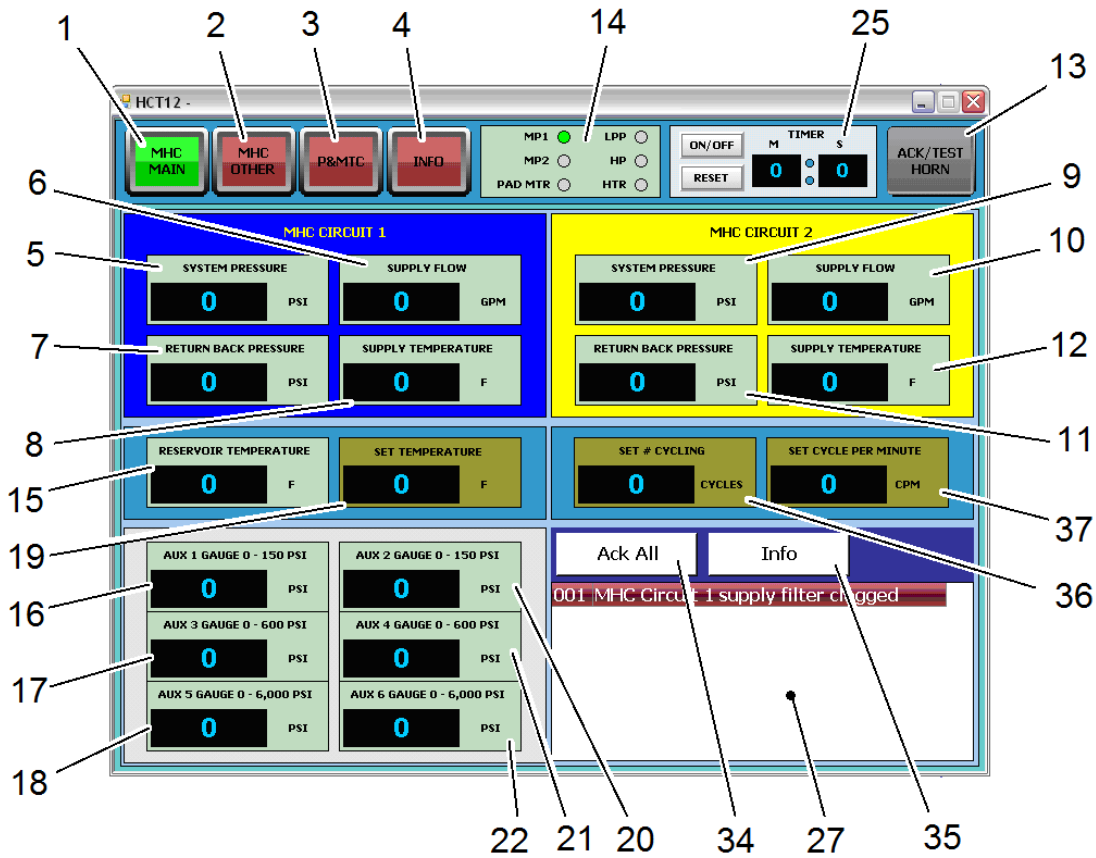

Figure 2. HMI Display, Main Screen

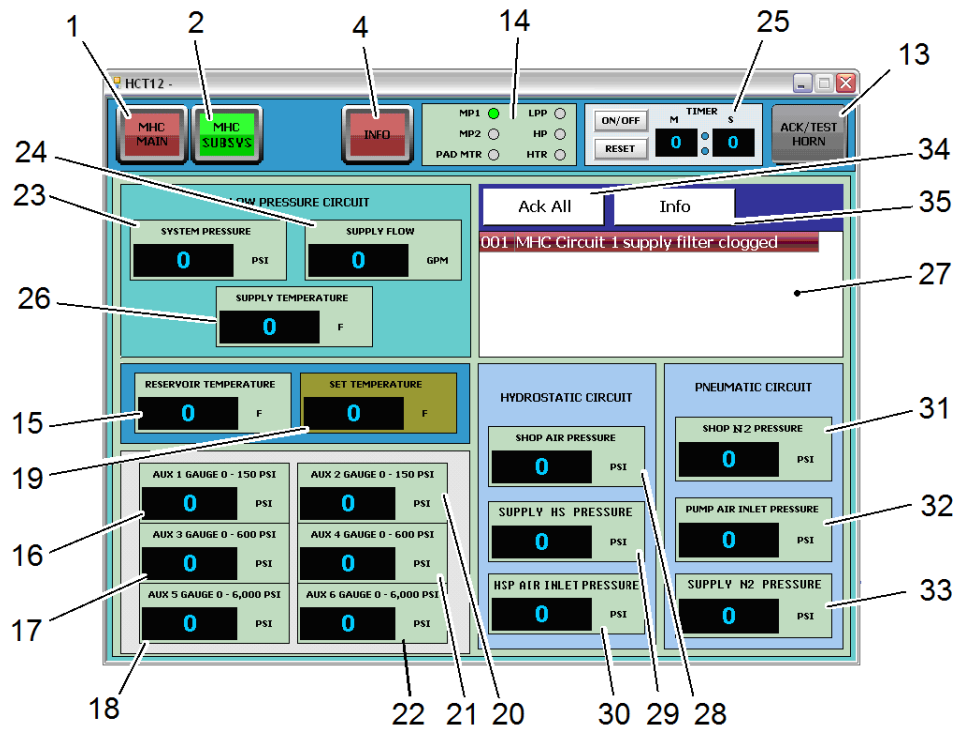

Figure 3. HMI Display, Hydrostatic and Pneumatic Circuits Screen

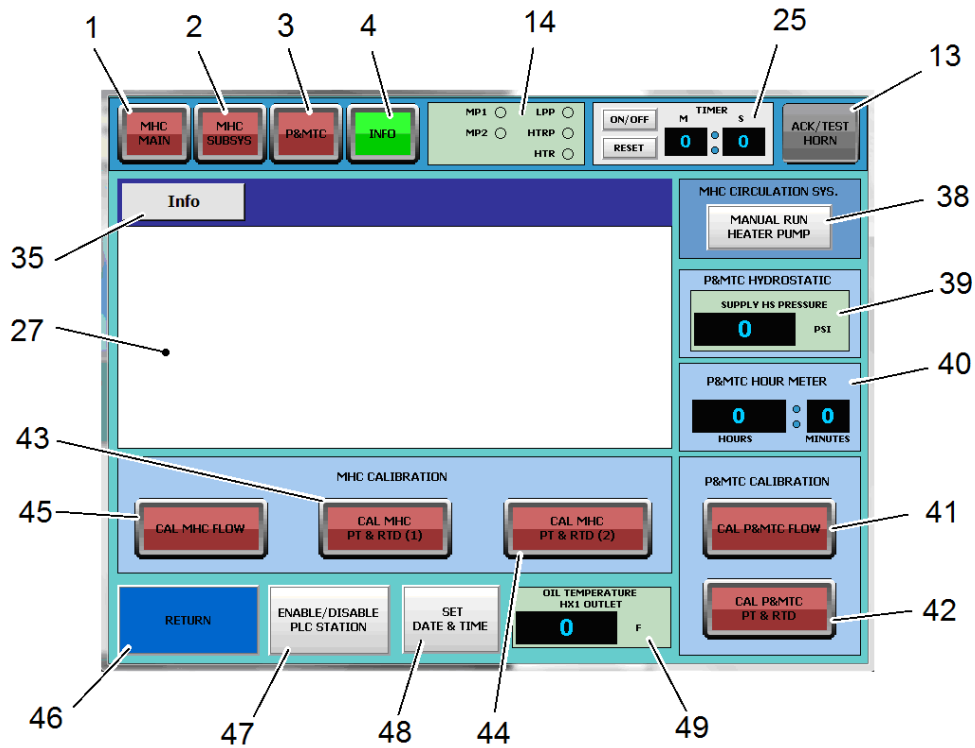

Figure 4. HMI Display, Info Screen



HII HCT-12 has been qualified and approved for the following requirements:

- 1- Operating Temperature.** The HCT-12 is able to operate in ambient conditions that range from 32^oF to 122^oF.
- 2- Storage Temperature.** Will range from -60^oF to 160^oF.
- 3- Electromagnetic Interference.** the HCT-12 is considered as equipment operating within a surface ship environment, below deck, of a metal-hulled vessel. Performed all tests in accordance with MIL-STD-461. The following tests of the standard are to be performed as a minimum: CE102, CS101, CS114, CS115, CS116, RE101, RE102, RS101 and RS103.
- 4- Voltage Spike.** The HCT-12 meets the requirements MIL-STD 1399, Section 300A, paragraph 5.3.3.
- 5- Power Interruption.** The HCT-12 meets the requirements MIL-STD 1399, Section 300A, paragraph 5.3.4.
- 6- Shock.** The HCT-12 meets the requirements of MIL-S-901, Grade B, Type A, deck mounted equipment, with mounting orientation unrestricted. The MHC is operating during the test.
- 7- Shipboard Vibration.** The HCT-12 meets the requirements as defined in MIL-STD-167, Type I and Type II while operating.
- 8- Transportation Vibration.** The HCT-12 is able to withstand vibration as defined in MIL-STD-810, Method 514.5, Procedure I (General Vibration), Platform: Truck/Trailer Category: Restrained Cargo
- 9- Operation under Tilt.** The HCT-12 is able to operate on a surface that is moving while being tilted 8.5° horizontally in any direction, regardless of fluid level.
- 10- Leakage.** The HCT-12 does not leak if tilted in any direction up to 15 degrees from the horizontal in any direction regardless of fluid level. Unit lines, fittings, and components downstream of and including the pump shall not leak when exposed to 1.5 times expected delivery pressure.
- 11- Humidity.** The HCT-12 meets the requirements of MIL-STD-810, Method 507.
- 12- Salt Fog.** The MHC meets the requirements of MIL-STD-810, Method 509.
- 13- Sound Attenuation.** Sound/noise levels created by the HCT-12 (exclusive of a UUT) does not more than 85 dba at the operator's location with the HCT-12 mounted two feet from the rear wall and operating both dynamic hydraulic circuits at their maximum capacity. The operator's location shall be designated as within 10 feet of the front of the HCT-12 and 5.5 feet above ground level.



Maintainability Demonstration Test

The HCT-12 meets all maintenance actions, corrective maintenance actions and required quantitative maintainability metrics in accordance with MIL-HDBK-470A.

Mean Time Between Failure. The HCT-12 has a mean time between failure (MTBF) of no less than 390 hours. A failure is defined as the HCT-12 inability to perform all required functions to the full extent of this specification. The MTBF requirement is in accordance with the requirements and provisions of MIL-HDBK-470A.

Mean Time to Repair. The HCT-12 has a mean time to repair (MTTR) of 4 hours or less. The MTTR is defined as the mean time required to perform any necessary corrective actions to recover from a failure. The MTTR requirement is in accordance with MIL-HDBK-470A.

Reliability Demonstration Test

The reliability test has been performed on the full range and capabilities of the MHC Pilot Production Unit (PPU) in accordance with MIL-HDBK-781A over 2000 hours without failures.

The predicted MTBF for HCT-12 obtained from the reliability predictions are significantly higher than the demonstrated reliability. The predicted MTBF is provided in Table below.

HCT-12 Predicted Failure Rates

Module	Predicted Failure Rate	MTBF	Required MTBF
HCT-12	446.52	2240	390